



Service Parts

S86NX- (OPP RH)

S86NX-(OPP_RH)_TT

S86NX-(OPP_RH)_DT

LH: Left Hand, RH: Right Hand

STD: Standard, OPP: Opposite

TT: Thermal Transfer, DT: Direct Thermal

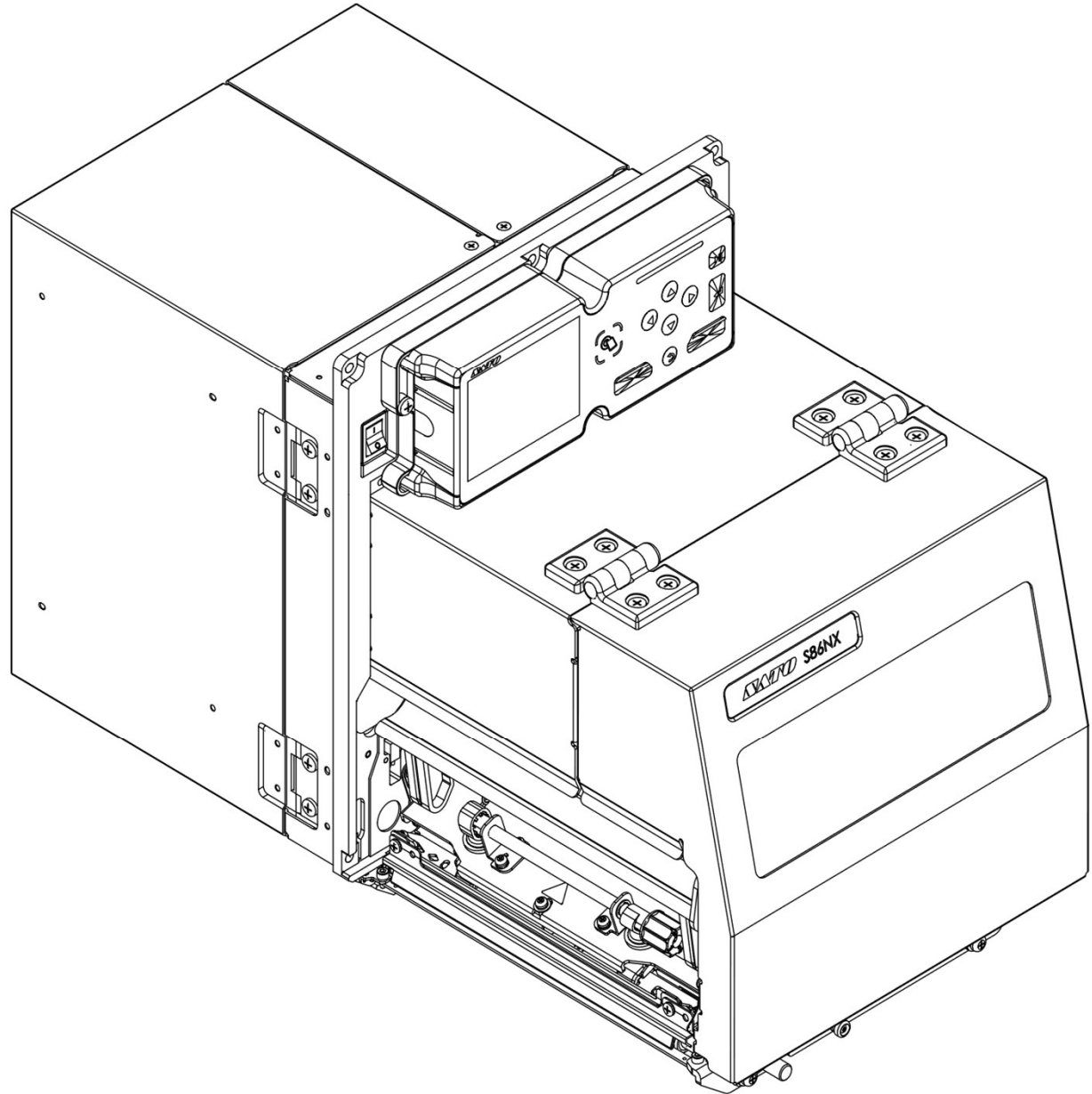

Version : S86NX-RH--r14-07-05-25SP

© 2022 SATO Corporation.

All rights reserved.

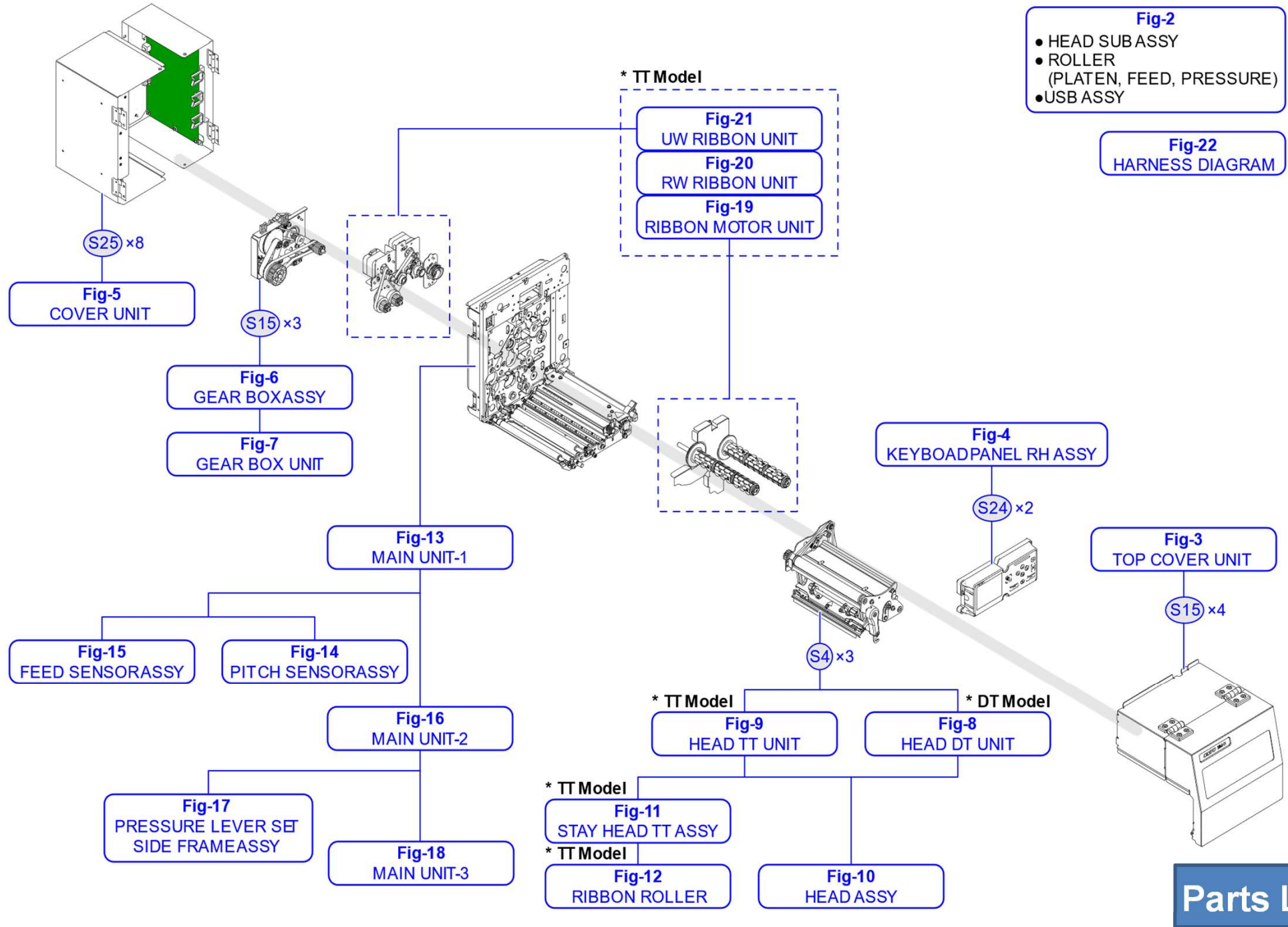

Drawing

No.	FIRST CODE	DESCRIPTION	NOTE
Fig-3		TOP COVER UNIT	
Fig-4		COVER UNIT	CONT PCB ASSY, POWER UNIT
Fig-5		KEYBOARD PANEL RH ASSY	
Fig-6		GEAR BOX ASSY	
Fig-7		GEAR BOX UNIT	
Fig-8		HEAD DT UNIT	* DT Model
Fig-9		HEAD TT UNIT	* TT Model
Fig-10		HEAD ASSY	
Fig-11		STAY HEAD TT ASSY	* TT Model
Fig-12		RIBBON ROLLER	* TT Model
Fig-13		MAIN UNIT-1	
Fig-14		PITCH SENSOR ASSY	IM/GAP-B PCB ASSY
Fig-15		FEED SENSOR ASSY	IM/GAP-A PCB ASSY
Fig-16		MAIN UNIT-2	
Fig-17		PRESSURE LEVER SET	
Fig-17		SIDE FRAME ASSY	
Fig-18		MAIN UNIT-3	
Fig-19		RIBBON MOTOR UNIT	* TT Model
Fig-20		RW RIBBON UNIT	* TT Model
Fig-21		UW RIBBON UNIT	* TT Model
Fig-22		HARNES DIAGRAM	
S4	MD3401021	PAN HEAD SCREW+SW+WS	
S15	MD4400822	PAN HEAD SCREW+SW+WL	
S24	MA2401428	BIND HEAD SCREW	
S25	MA2400628	BIND HEAD SCREW	

TOP COVER UNIT

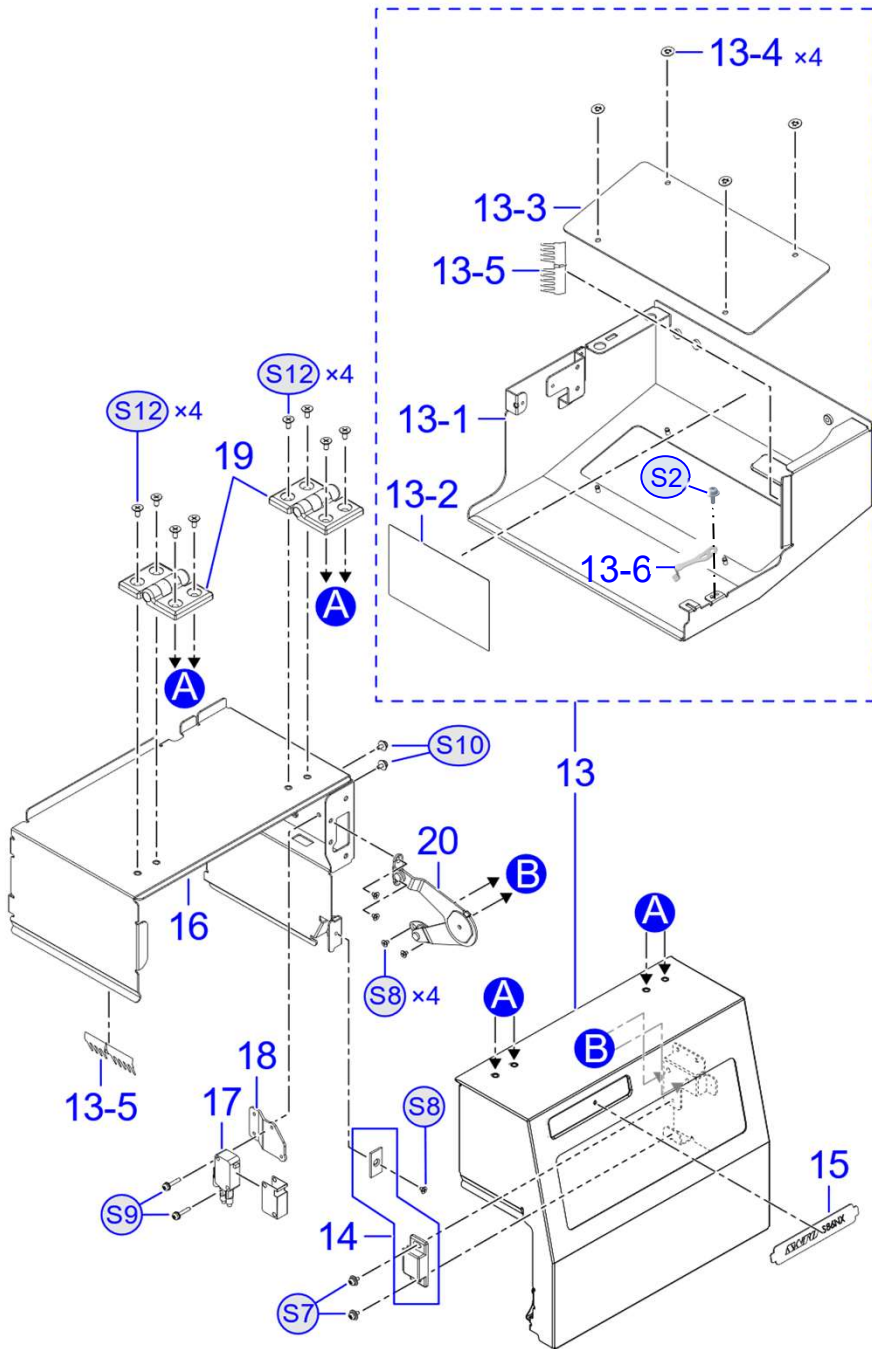

No.	FIRST CODE	DESCRIPTION	NOTE
13	R41813201	TOP OPEN COVER RH ASSY	
13-1	R40295106	TOP OPEN COVER RH SET	
13-2	Q05486500	ROUTE STICKER RH	
13-3	P14038100	WINDOW	
13-4	MV8300030	PUSH NUT	
13-5	P16765000	ANTI STATIC SHEET	* TT Model
13-6	P65674102	SPRING(SHIELD GASKET)	
14	P54470000	MAGNET CATCH	
15	P64576300	LOGO PLATE(S86NX)	
16	R41806302	TOP COVER(6)RH SET SILK	
17	R40887101	S84-86NX COVER SWITCH CABLE SET-LF	
18	P64205902	NUT PLATE RH	
19	P64993900	HINGE	
20	P54469000	STAY (RIGHT)	
S2	MD4300822	PAN HEAD SCREW+SW+WL	
S7	MD4300628	PAN HEAD SCREW+SW+WL	
S8	MA1300622	FLAT HEAD SCREW	
S9	MD3301422	PAN HEAD SCREW+SW+WS	
S10	MD3300621	PAN HEAD SCREW+SW+WS	
S12	MA1400828	FLAT HEAD SCREW	

NOTE *1: Recommended Spare parts

GEAR BOX ASSY

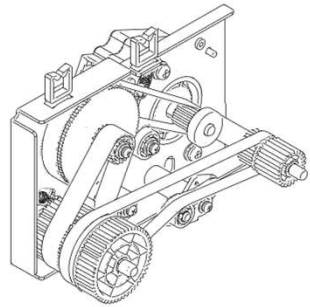

Fig-6 & Fig-7 36

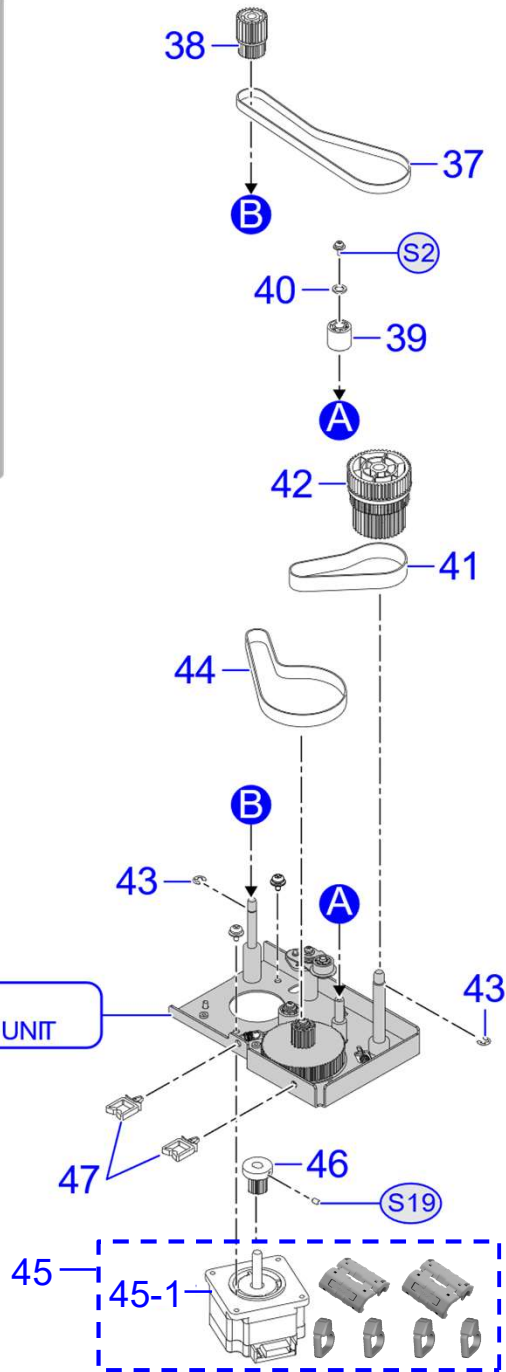
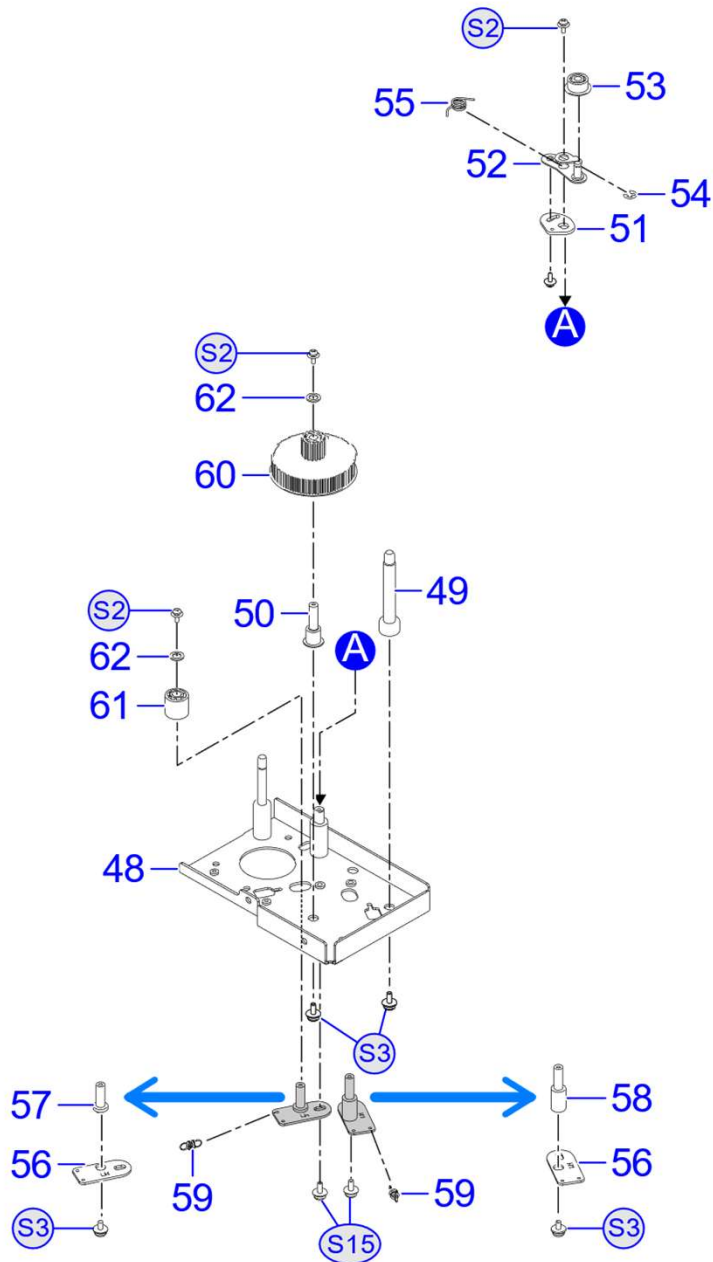

Fig-7
GEAR BOX UNIT

No.	FIRST CODE	DESCRIPTION	NOTE
36	R39951104	GEAR BOX RH ASSY	
37	P34928000	TIMING BELT(S2M 340)	
38	P17070010	GEAR(FEED)	
39	P53878000	TENSION ROLLER	
40	P54440000	POLY SLIDER WASHER	
41	P46271000	TIMING BELT(S3M*192)	
42	P34348001	GEAR PULLEY(52/64/38)	
43	ND0040022	E SNAP RING	
44	P46270000	TIMING BELT(S2M*274)	
45	R44881500	S84-86NX FEED MOTOR ASSY	
45-1	K00475000	STEPPING MOTOR-LF	
46	P11157001	MO PULLEY	
47	P11523000	WIRE SADDLE	
S2	MD4300822	PAN HEAD SCREW+SW+WL	
S15	MD4400822	PAN HEAD SCREW+SW+WL	
S19	MJ1400528	HEX SOCKET SET SCREW	
Fig-7		<u>GEAR BOX UNIT</u>	

NOTE *1: Recommended Spare parts

GEAR BOX UNIT



No.	FIRST CODE	DESCRIPTION	NOTE
48	R21106001	GEAR FRAME SET(RH)	
49	P17071020	SHAFT(GEAR FRAME A)	
50	P46249000	POST(PULLEY)	
51	P17280000	TENSION LINK	
52	R07927000	TENSION PLATE(RH)SET	
53	P13863010	TENSION ROLLER	
54	ND0040022	E SNAP RING	
55	P17810010	SPRING(TENSION)(RH)	
56	P46247000	TENSION BRACKET	
57	P46240000	POST(TENSION)(A)	
58	P46241000	POST(TENSION)(B)	
59	P17402000	SPRING(BELT TENSION)	
60	P46802000	PULLEY(18/90)	
61	P53878000	TENSION ROLLER	
62	P54440000	POLY SLIDER WASHER	
S2	MD4300822	PAN HEAD SCREW+SW+WL	
S3	MD4401028	PAN HEAD SCREW+SW+WL	
S15	MD4400822	PAN HEAD SCREW+SW+WL	

NOTE *1: Recommended Spare parts

HEAD DT UNIT

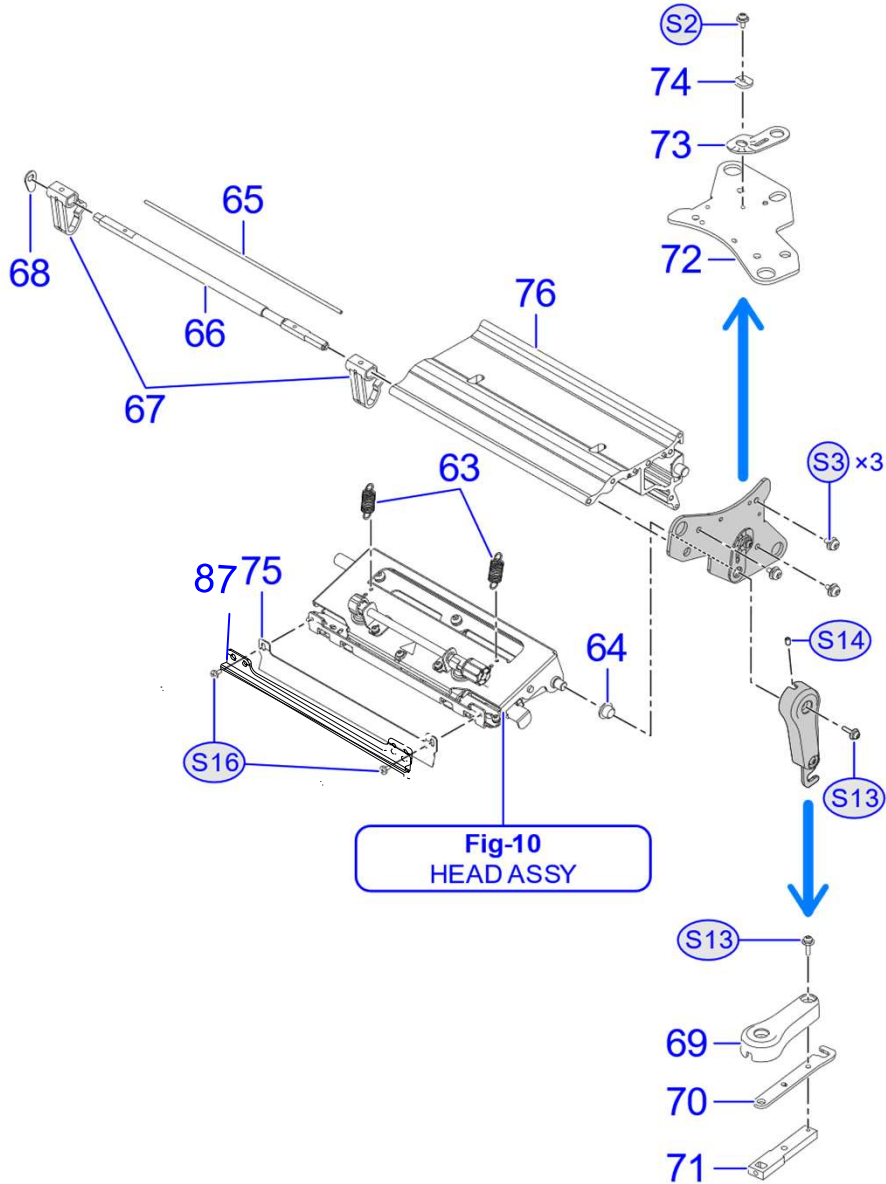

No.	FIRST CODE	DESCRIPTION	NOTE
63	P63687902	SPRING(HEAD OPEN)	
64	P24424000	FLANGE BUSH B	
65	P63874501	SPRING SHAFT(6)	
66	P46062000	SHAFT(HEAD CAM)	
67	P17052000	PRESSURE CAM	
68	P17026000	SENSOR ARM	
69	P53743000	LOCK LEVER	
70	P53742000	LOCK PLATE	
71	P53744000	HEAD LOCK HANDLE	
72	P64476301	SIDE PLATE RH	
73	P40906000	ADJUST PLATE	
74	PL2720100	ADJUST COLLAR	
75	P46496001	RIBBON PLATE	
76	R40600502	STAY HEAD(6)SET	
87	P65323902	RIBBON ADJUST PLATE(6)	
S2	MD4300822	PAN HEAD SCREW+SW+WL	
S3	MD4401028	PAN HEAD SCREW+SW+WL	
S13	MD4301228	PAN HEAD SCREW+SW+WL	
S14	MJ1400524	HEX SOCKET SET SCREW(W-POINT)	
S16	MA2300628	BIND HEAD SCREW	
Fig-10		<u>HEAD ASSY</u>	

NOTE *1: Recommended Spare parts

HEAD TT UNIT

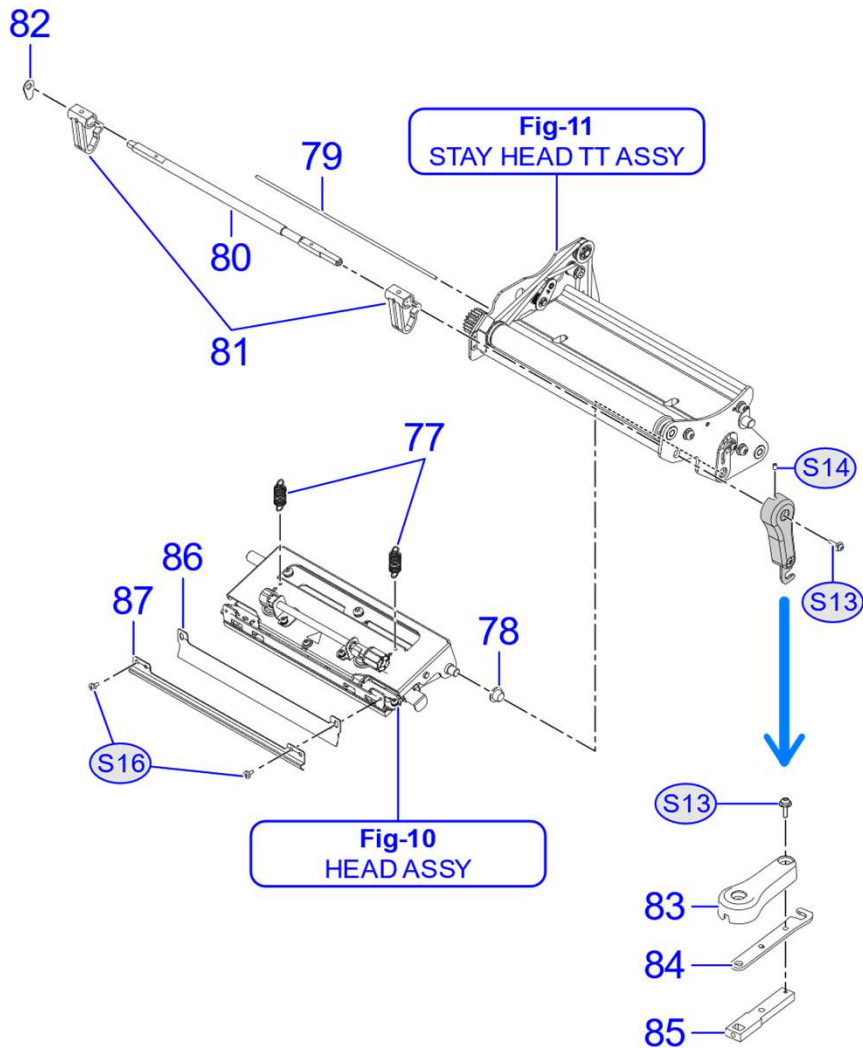

No.	FIRST CODE	DESCRIPTION	NOTE
77	P63687902	SPRING(HEAD OPEN)	
78	P24424000	FLANGE BUSH B	
79	P63874501	SPRING SHAFT(6)	
80	P46062000	SHAFT(HEAD CAM)	
81	P17052000	PRESSURE CAM	
82	P17026000	SENSOR ARM	
83	P53743000	LOCK LEVER	
84	P53742000	LOCK PLATE	
85	P53744000	HEAD LOCK HANDLE	
86	P46496001	RIBBON PLATE	
87	P65323902	RIBBON ADJUST PLATE(6)	
S13	MD4301228	PAN HEAD SCREW+SW+WL	
S14	MJ1400524	HEX SOCKET SET SCREW(W-POINT)	
S16	MA2300628	BIND HEAD SCREW	
Fig-10		<u>HEAD ASSY</u>	
Fig-11		<u>STAY HEAD TT ASSY</u>	

NOTE *1: Recommended Spare parts

HEAD ASSY

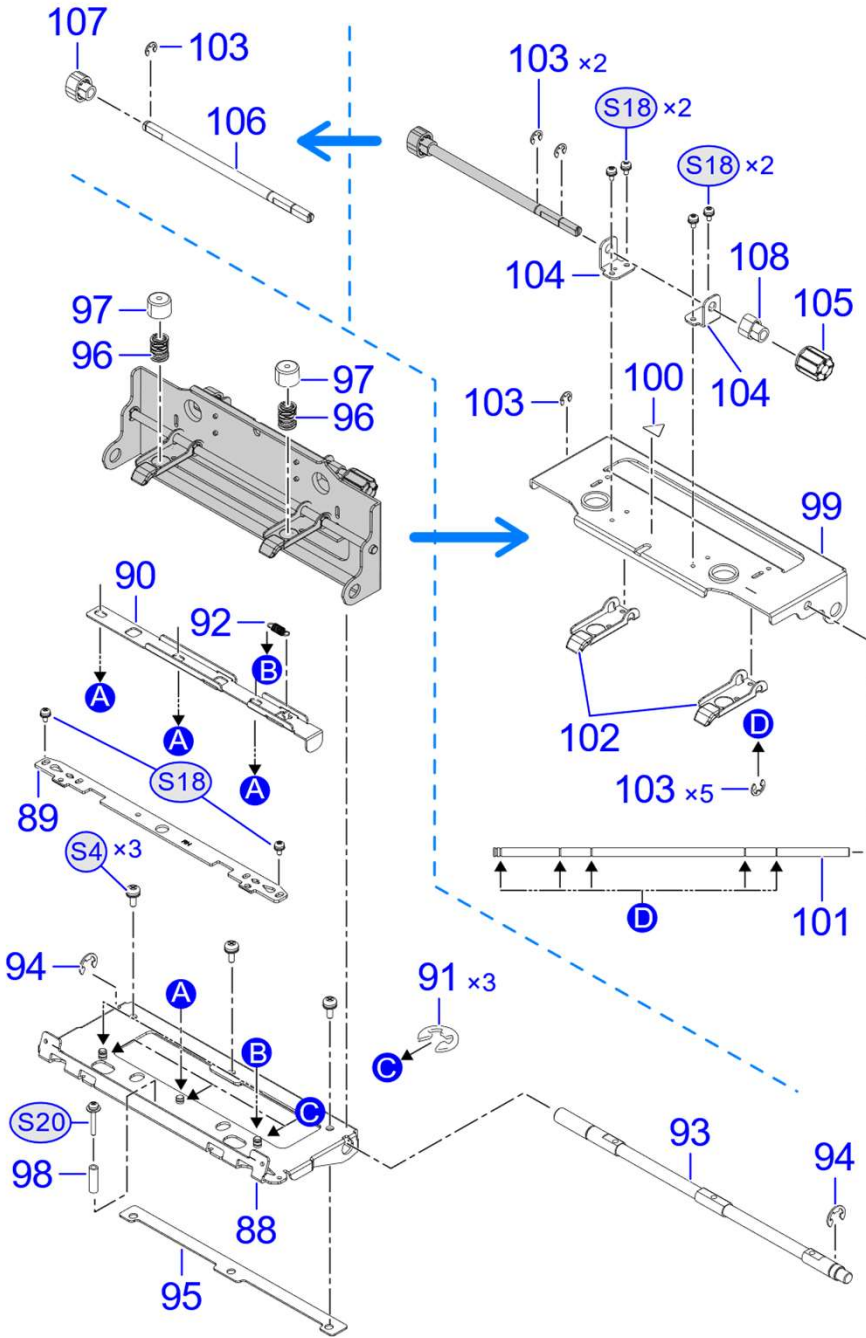

No.	FIRST CODE	DESCRIPTION	NOTE
88	R40613201	HEAD BR(6)SET	
89	P45561000	ADJUST PLATE(HEAD)	
90	P64642302	RELEASE LEVER(6)	
91	ND0030030	E SNAP RING	
92	P17132010	SPRING(RELEASE)	
93	P45466000	SHAFT(HEAD)	
94	ND0070022	E SNAP RING	
95	P45588000	SPACER(HEAD)	
96	P46958000	SPRING(HEAD)	
97	P17118000	SPRING CAP	
98	P56626100	COLLAR(3.1*5*16.7)	
99	P46797000	HEAD TOP BR(RH)	
100	QC6524200	STICKER(CAUTION HOT)	
101	P45726000	SHAFT(ARM)	
102	P17532000	PRESSURE ARM	
103	ND0040022	E SNAP RING	
104	P17115010	PRESSURE BR A	
105	P17124100	KNOB(HEAD PRESSURE)	
106	P45778000	SHAFT(HEAD PRESSURE B)	
107	P17122000	HEAD PRESSURE A	
108	P17123000	HEAD PRESSURE B	
S4	MD3401021	PAN HEAD SCREW+SW+WS	
S18	MD3300621	PAN HEAD SCREW+SW+WS	
S20	MD4302022	PAN HEAD SCREW+SW+WL	

NOTE *1: Recommended Spare parts

STAY HEAD TT ASSY

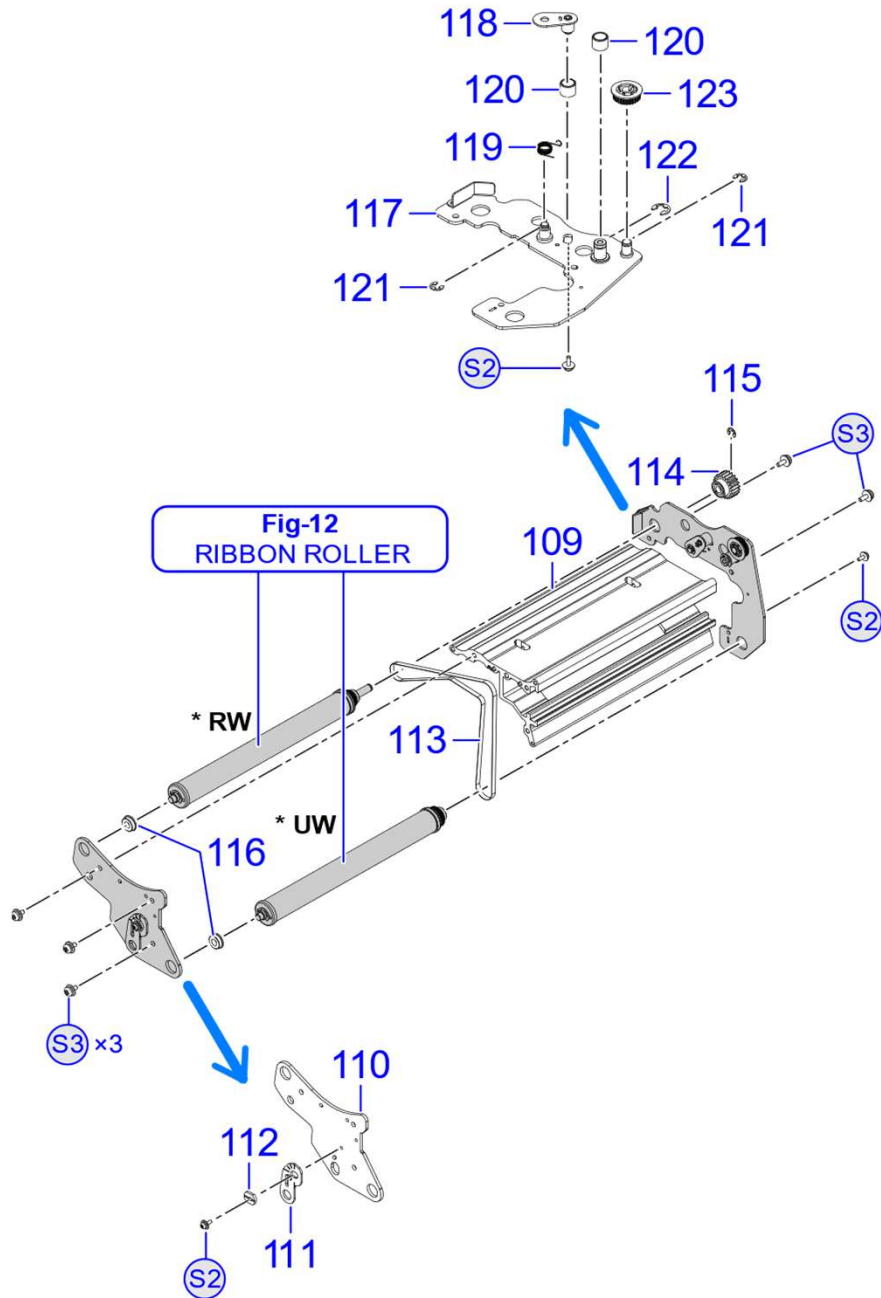

No.	FIRST CODE	DESCRIPTION	NOTE
109	R40600502	STAY HEAD(6)SET	
110	P64476301	SIDE PLATE RH	
111	P40906000	ADJUST PLATE	
112	PL2720100	ADJUST COLLAR	
113	P64171900	TIMING BELT (S2M 464)	
114	P23465000	ROLLER GEAR(RW)	
115	ND0040022	E SNAP RING	
116	P17891000	GRITRON SE	
117	R40551201	SUB BASE RH SET	
118	R08448000	TENSIONER BR(SUB)SET	
119	P65113900	SPRING(TENSIONER)RH	
120	P18887000	OILES BEARING	
121	ND0040022	E SNAP RING	
122	ND0060030	E RING	
123	P13911000	PULLEY(S2M 28)	
S2	MD4300822	PAN HEAD SCREW+SW+WL	
S3	MD4401028	PAN HEAD SCREW+SW+WL	
Fig-12		<u>RIBBON ROLLER</u>	

NOTE *1: Recommended Spare parts

RIBBON ROLLER (UW) SUB ASSY

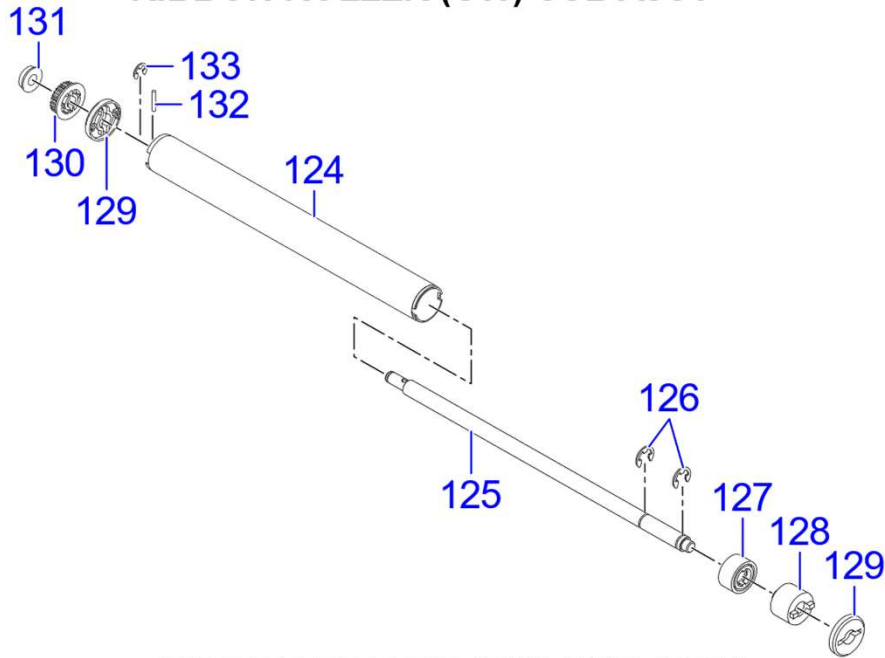

RIBBON ROLLER (RW) SUB ASSY

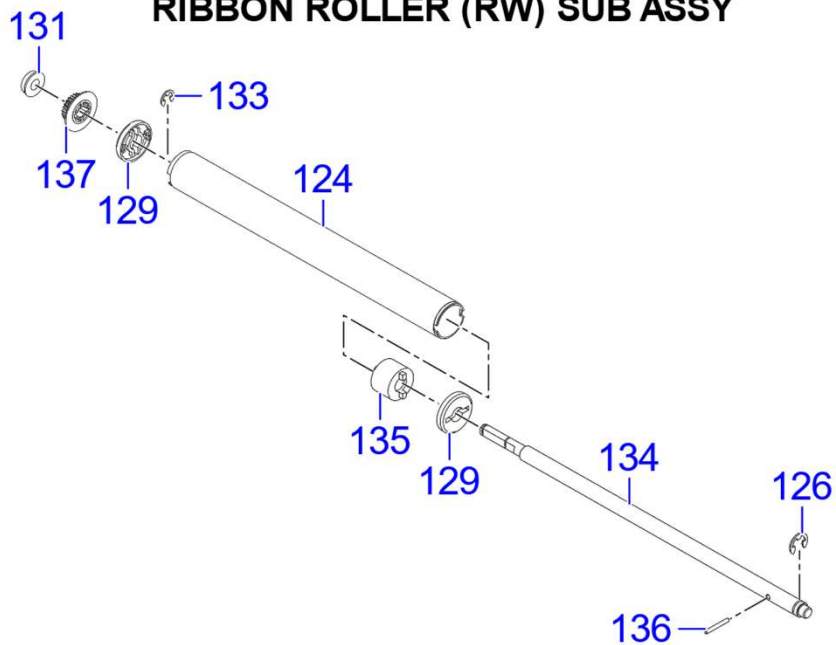

No.	FIRST CODE	DESCRIPTION	NOTE
RIBBON ROLLER (UW) SUB ASSY			
124	R21520000	RIBBON ROLLER SET	
125	P63876501	SHAFT(ROLLER UW)(6)	
126	ND0060030	E RING	
127	P14225000	ONEWAY CLUTCH	
128	P19384000	TORQUE LIMITER	
129	P17044000	ROLLER BR	
130	P13911000	PULLEY(S2M 28)	
131	P17891000	GRITRON SE	
132	NG2201230	STRAIGHT PIN	
133	ND0040022	E SNAP RING	
RIBBON ROLLER (RW) SUB ASSY			
124	R21520000	RIBBON ROLLER SET	
126	ND0060030	E RING	
129	P17044000	ROLLER BR	
131	P17891000	GRITRON SE	
133	ND0040022	E SNAP RING	
134	P63876401	SHAFT(ROLLER RW)(6)	
135	P08554000	TORQUE LIMITER	
136	NG2201630	PARALLEL PIN	
137	P63366102	PULLEY(S2M 24)	

NOTE *1: Recommended Spare parts

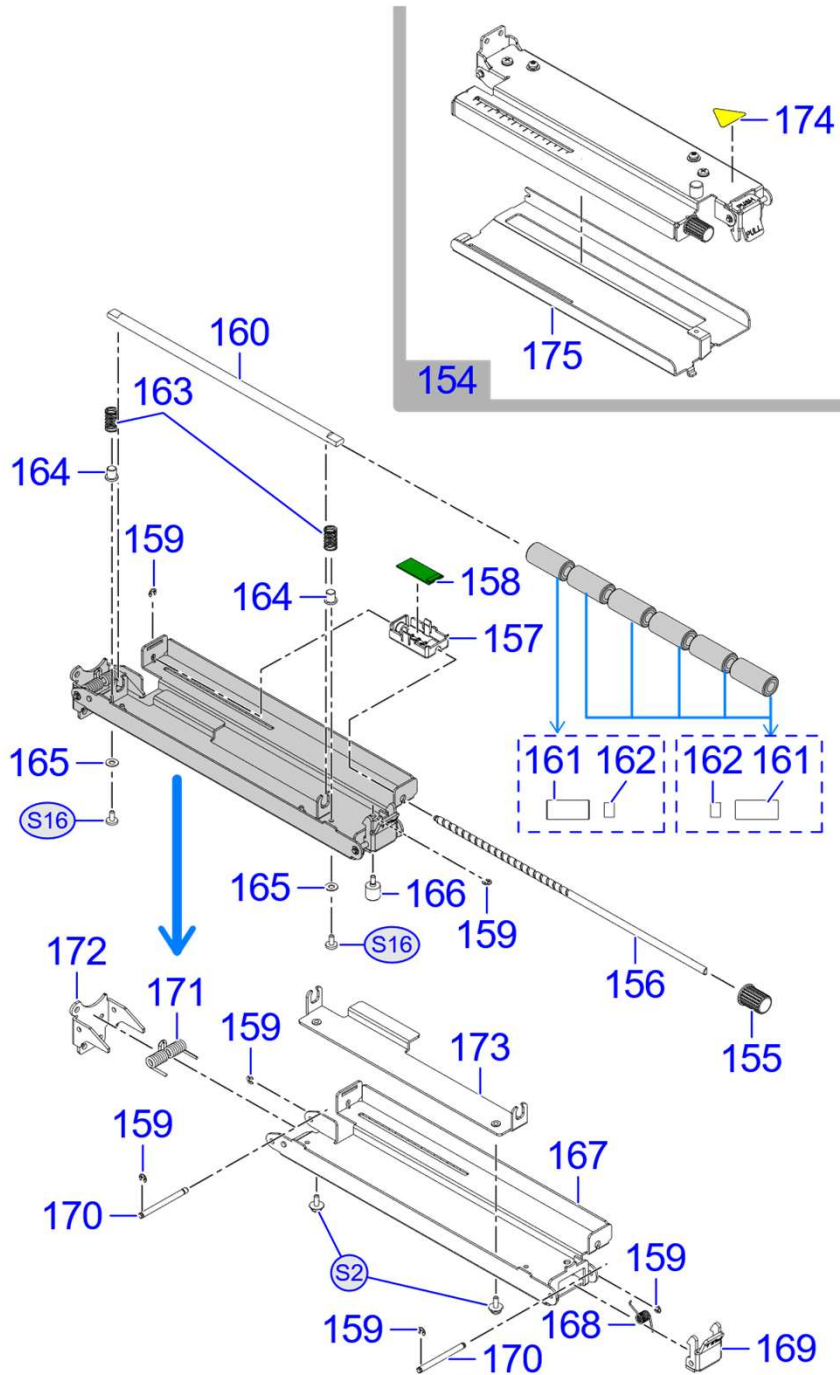

No.	FIRST CODE	DESCRIPTION	NOTE
154	R41835101	FEED BRACKET(6)RH S/A	
155	P15930100	KNOB(GAP SENSOR)	
156	P46626000	SCREW SHAFT(SENSOR)	
157	P22218010	SENSOR HOLDER	
158	R29053000	S84-86-IM/GAP-A PCB ASSY -LF	*1
159	ND0020030	E SNAP RING	
160	P46535000	SHAFT(ROLLER BR)	
161	R00603000	ROLLER(6.1*12*26)	
162	PE3720500	ROLLER (6.1*9*6)	
163	P22221000	SPRING(ROLLER BR)	
164	PE2730300	STOPPER COLLAR	
165	NA1030022	PLAIN WASHER	
166	P55046001	KNOB SCREW	
167	P54407000	FEED BRACKET(RH)	
168	P17107000	SPRING(HOOK)(LH)	
169	P54305000	HOOK	
170	P17105000	SHAFT(FEED BR)	
171	P22214000	SPRING(FEED BR)	
172	P63119903	HINGE(FEED BR) RH	
173	P54397001	ROLLER BR(RH)	
174	Q04255000	STICKER(CAUTION)	
175	P54404001	SENSOR COVER(RH)	
S2	MD4300822	PAN HEAD SCREW+SW+WL	
S16	MA2300628	BIND HEAD SCREW	

NOTE *1: Recommended Spare parts

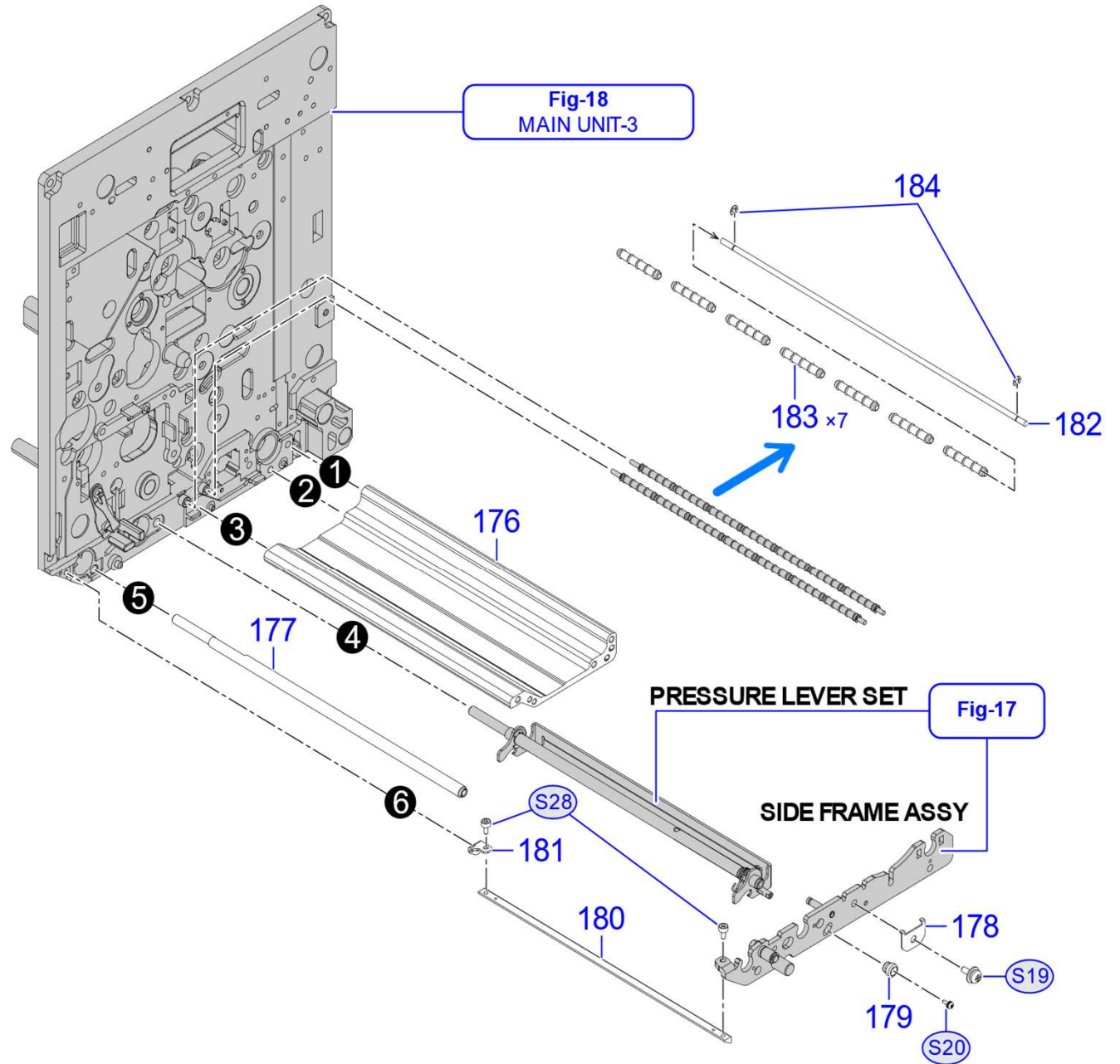
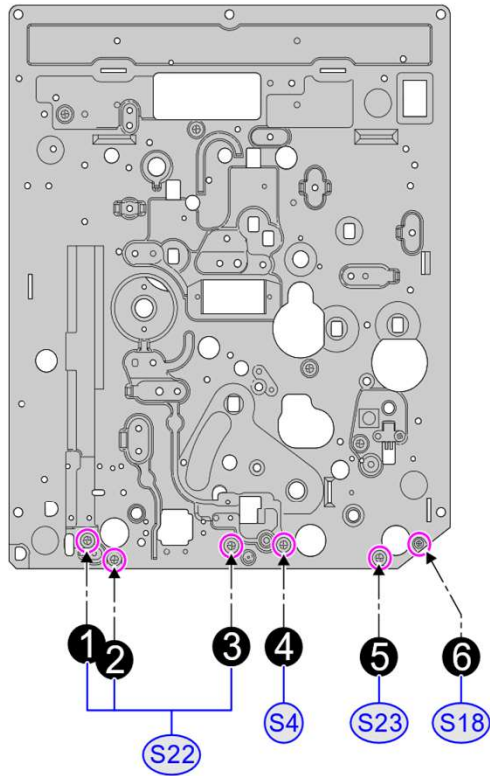

Parts List

Drawing

No.	FIRST CODE	DESCRIPTION	NOTE
176	P46330000	STAY(FRAME)	
177	P45308000	SHAFT(FEED)	
178	P13725000	ROLLER GUIDE	
179	P15937100	KNOB(HEAD SLIDE)	
180	P46527000	DISPENSE BAR(6)	
181	P17803010	DISPENSE GUIDE B(RH)	
182	P46567000	SHAFT(SUB ROLLER)	
183	PE1A20000	DEMAND ROLLER(B)	
184	ND0020030	E SNAP RING	
S4	MD3401021	PAN HEAD SCREW+SW+WS	
S18	MD3300621	PAN HEAD SCREW+SW+WS	
S19	MD4401028	PAN HEAD SCREW+SW+WL	
S20	MD3200622	PAN HEAD SCREW+SW+WS	
S22	MD3401422	PAN HEAD SCREW+SW+WS	
S23	MA0401022	PAN HEAD SCREW	
S28	MN0300624	HEX SOCKET HEAD CAP SCREW	
Fig-17		<u>PRESSURE LEVER SET</u>	
Fig-17		<u>SIDE FRAME ASSY</u>	
Fig-18		<u>MAIN UNIT-3</u>	

NOTE *1: Recommended Spare parts

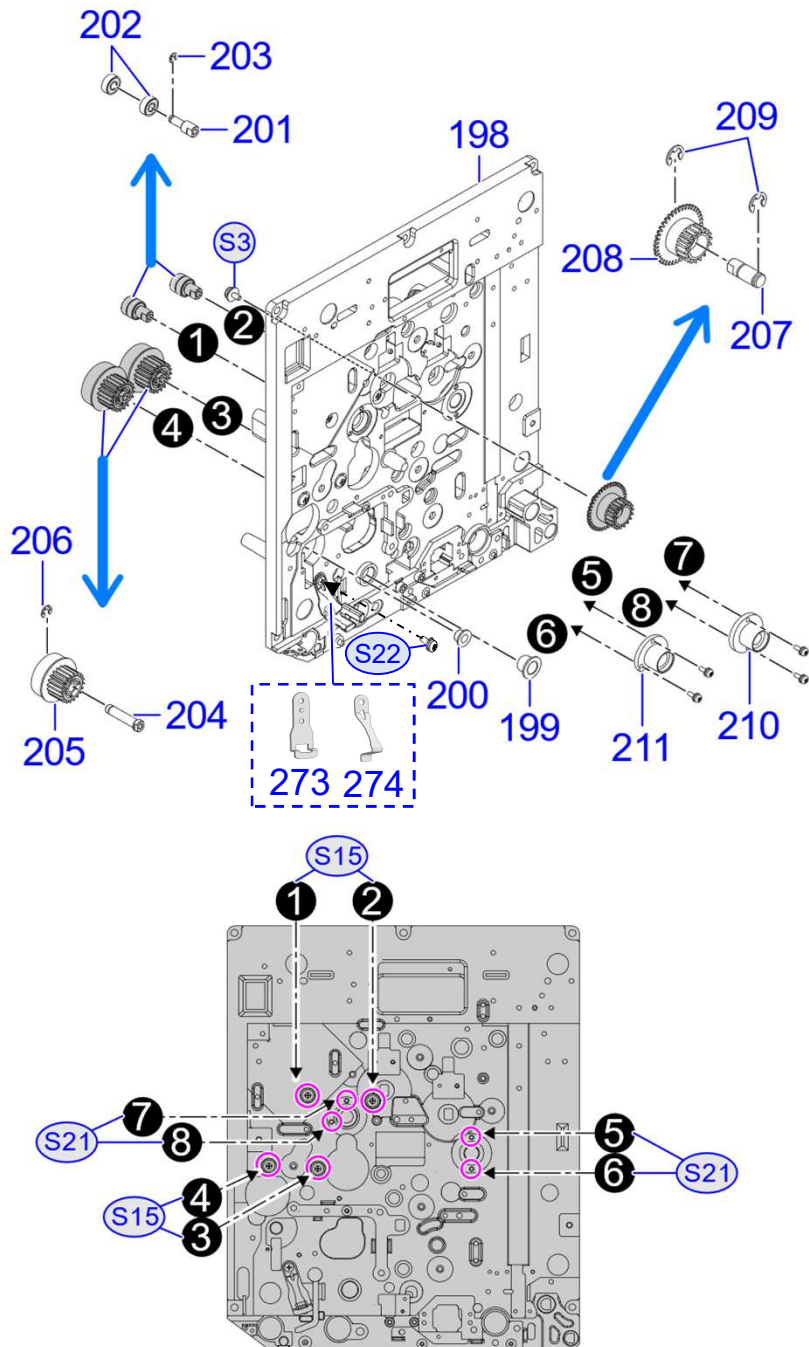

No.	FIRST CODE	DESCRIPTION	NOTE
198	P17093048	ENGINE FRAME(RH)	
199	P24423000	FLANGE BUSH A	
200	P17470000	OILESS BEARING	
201	P44235000	SHAFT(TENSION ROLLER)	* TT Model
202	P42541000	BEARING	* TT Model
203	ND0030030	E SNAP RING	* TT Model
204	P13822000	SHAFT(GEAR PULLEY)	* TT Model
205	P13908000	GEAR PULLEY(20/48)	* TT Model
206	ND0040022	E SNAP RING	* TT Model
207	P13821000	SHAFT(SLIT GEAR)	* TT Model
208	P13907000	SLIT GEAR(18)	* TT Model
209	ND0060030	E RING	* TT Model
210	P18754000	SHAFT(BOSS GUIDE UW)	* TT Model
211	P18755000	SHAFT(BOSS GUIDE RW)	* TT Model
273	P65340003	SPRING BR	
274	P65674102	SPRING(SHIELD GASKET)	
S3	MD4401028	PAN HEAD SCREW+SW+WL	* TT Model
S15	MD4400822	PAN HEAD SCREW+SW+WL	* TT Model
S21	MD3300822	PAN HEAD SCREW+SW+WS	* TT Model
S22	MA2300622	BIND HEAD SCREW	

NOTE *1: Recommended Spare parts

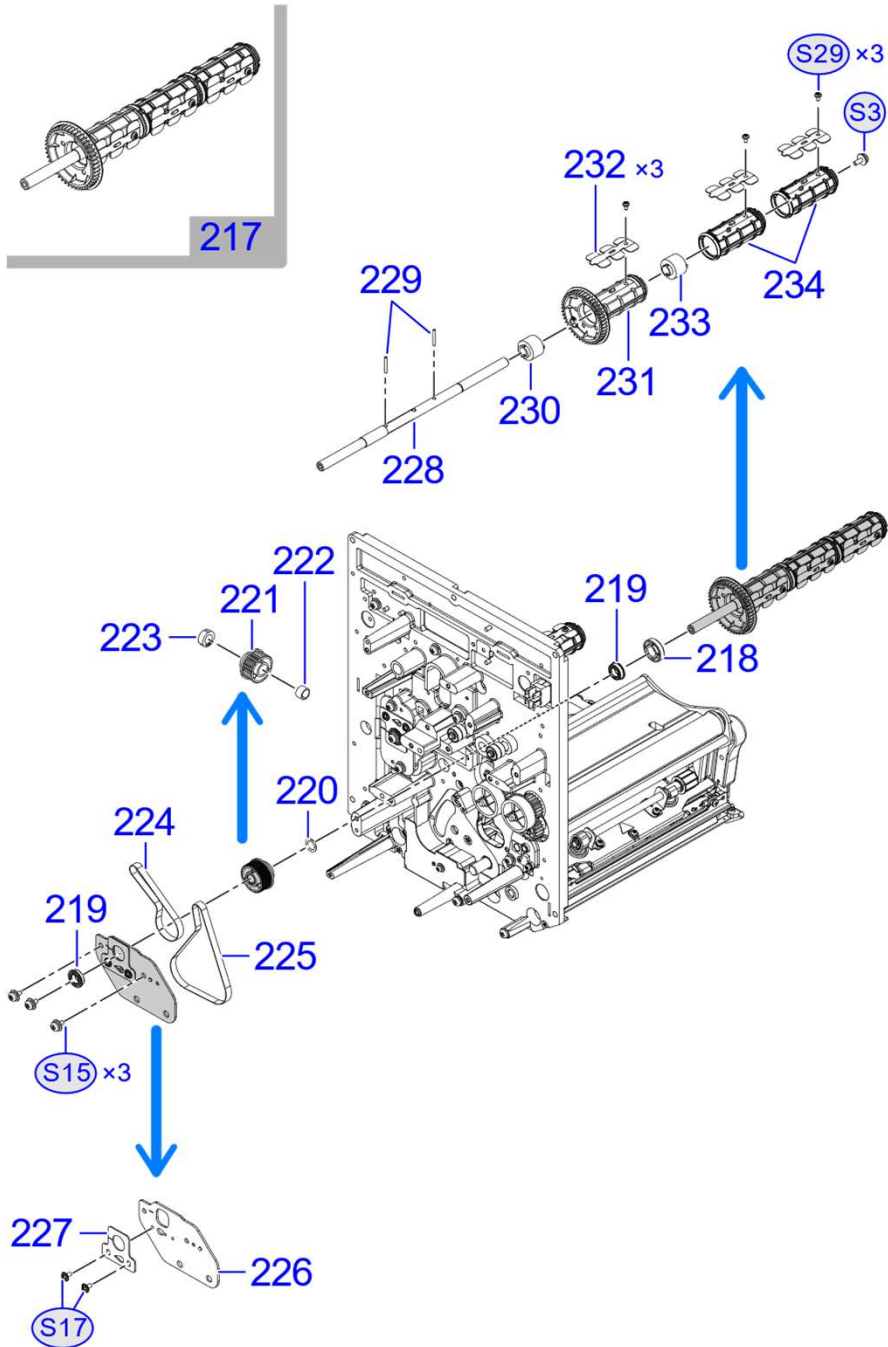

No.	FIRST CODE	DESCRIPTION	NOTE
217	R42348801	RIBBON BOSS(RW)(6)S/A	
218	P17947000	COLLAR(BOSS)	
219	PT1114080	BALL BEARING	
220	PT9740300	POLY SLIDER	
221	P13909000	PULLEY(S2M 40)	
222	P18044000	ONE WAY CLUTCH	
223	P20916000	DRY METAL	
224	P17886000	TIMING BELT	
225	PU3256060	TIMING BELT	
226	P17021000	PULLEY FRAME	
227	P17737000	BEARING HOLDER	
228	P56111200	SHAFT BOSS (RW)	
229	NG2201630	PARALLEL PIN	
230	P08554000	TORQUE LIMITER	
231	P17049010	RIBBON BOSS(GEAR)	
232	P17016000	BOSS SPRING	
233	P12267000	TORQUE LIMITER	
234	P17050010	RIBBON BOSS	
S3	MD4401028	PAN HEAD SCREW+SW+WL	
S15	MD4400822	PAN HEAD SCREW+SW+WL	
S17	P56159700	TP SCREW	
S29	MH0300522	PAN HEAD P TIGHT SCREW	

NOTE *1: Recommended Spare parts

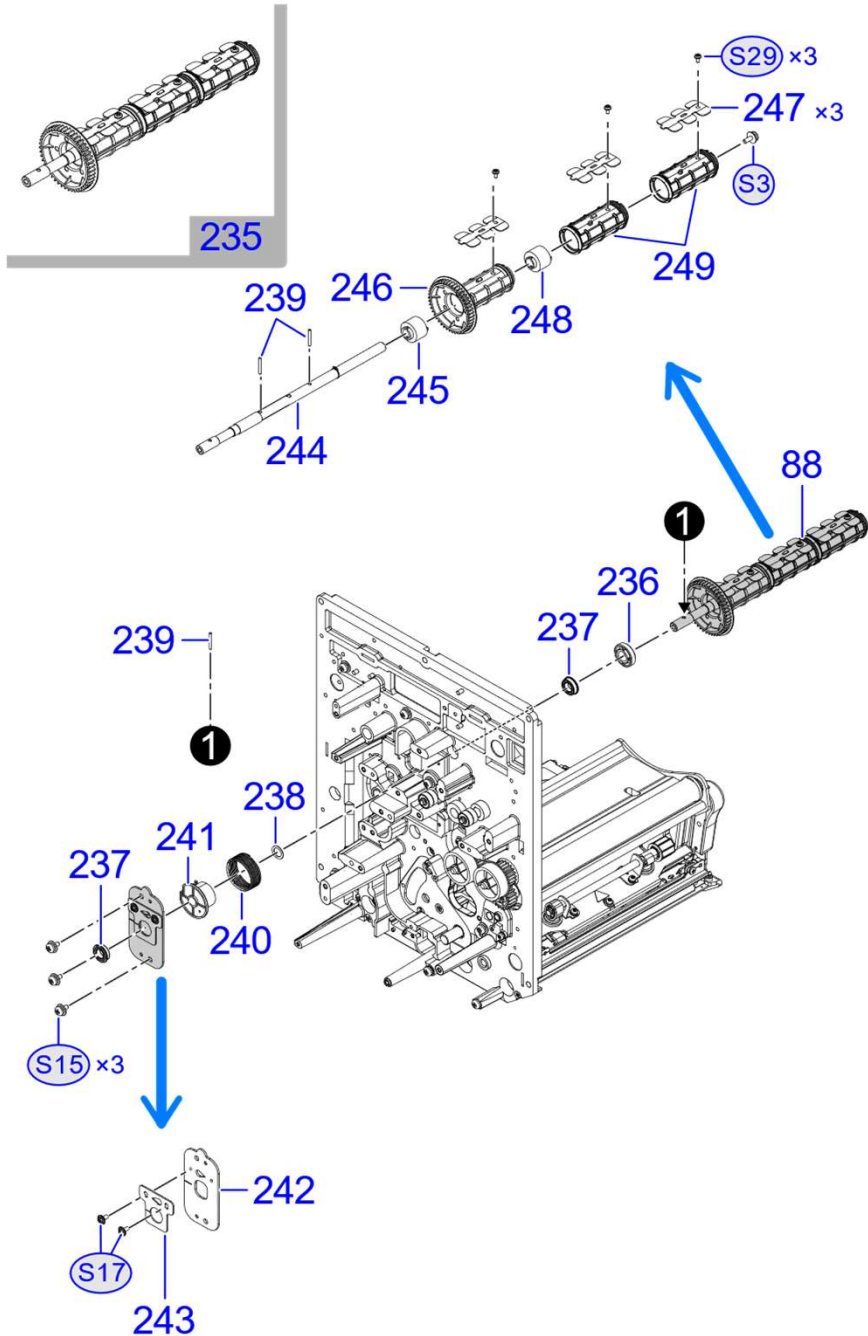

UW RIBBON UNIT

No.	FIRST CODE	DESCRIPTION	NOTE
235	R42348901	RIBBON BOSS(UW)(6)S/A	
236	P17947000	COLLAR(BOSS)	
237	PT1114080	BALL BEARING	
238	PT9740300	POLY SLIDER	
239	NG2201630	PARALLEL PIN	
240	P17059010	SPRING(BACK)	
241	P17039000	BF STOPPER	
242	P17950000	PLATE(RIBBON UW)	
243	P17737000	BEARING HOLDER	
239	NG2201630	PARALLEL PIN	
244	P56111300	SHAFT BOSS (UW)	
245	P08554000	TORQUE LIMITER	
246	P17049010	RIBBON BOSS(GEAR)	
247	P17016000	BOSS SPRING	
248	P12267000	TORQUE LIMITER	
249	P17050010	RIBBON BOSS	
S3	MD4401028	PAN HEAD SCREW+SW+WL	
S15	MD4400822	PAN HEAD SCREW+SW+WL	
S17	P56159700	TP SCREW	
S29	MH0300522	PAN HEAD P TIGHT SCREW	

NOTE *1: Recommended Spare parts

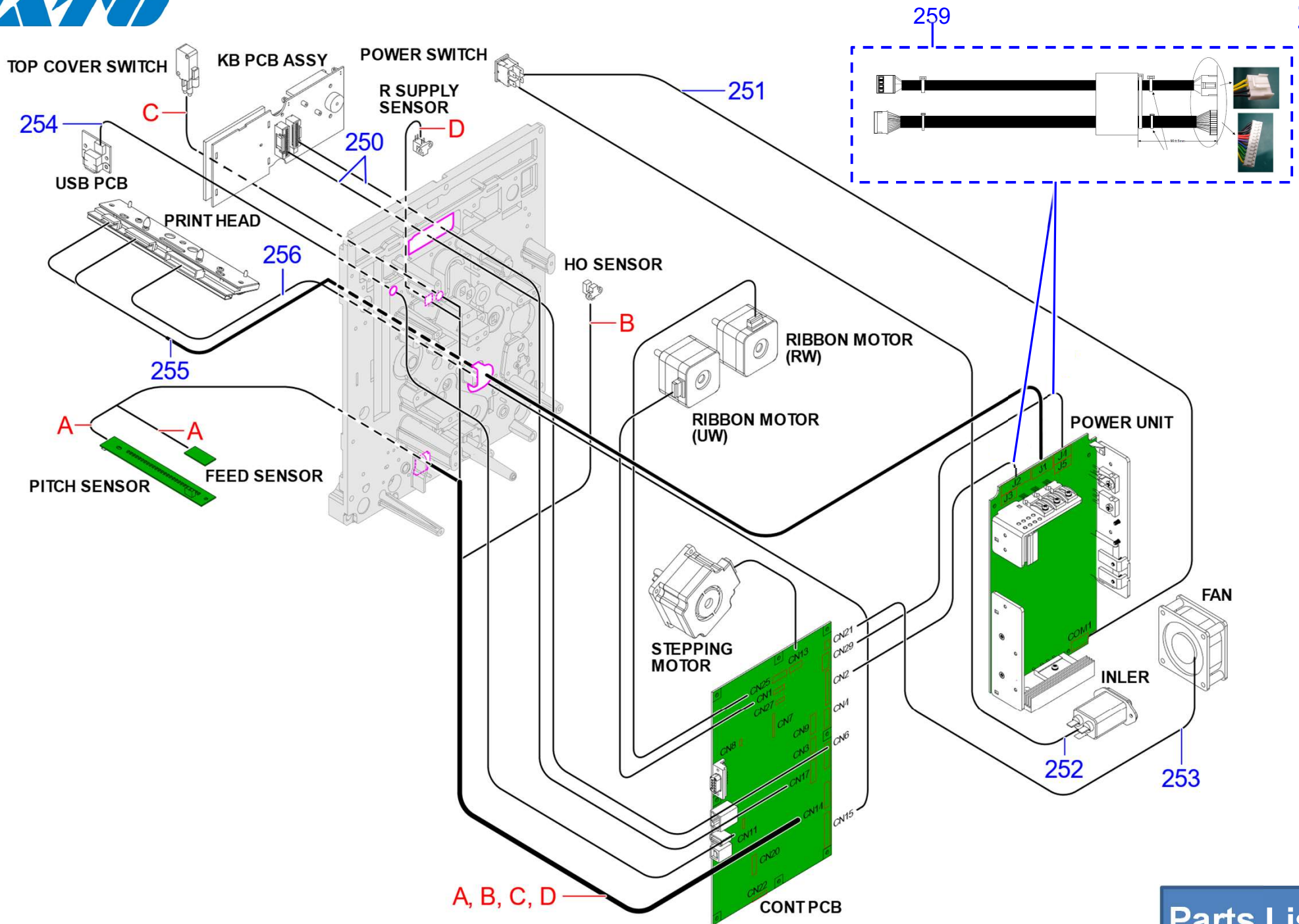

[Parts List](#)



Harness

[TOP](#)

No.	FIRST CODE	DESCRIPTION	NOTE
250	R40887600	S84-86NX KB CABLE SET-LF	CONT PCB (CN6) - KB PCB ASSY CONT PCB (CN17) - KB PCB ASSY
251	R43125100	S84-86NX-AC LINE CABLE SET-LF	POWER UNIT (CON1) - POWER SW
252	R40887200	S84-86NX INLET CABLE SET-LF	INLET - POWER SW
253	R21221000	S84-86-FAN CABLE SET-LF	CONT PCB (CN21) - FAN
254	R19302000	USBH CABLE SET-LF	CONT PCB (CN11) - USB PCB
255	R21155000	S86-HEAD POWER CABLE SET-LF	POWER UNIT (J1) - PRINT HEAD
256	R43173100	S84NX-HEAD CABLE SET-LF	CONT PCB (CN15) - PRINT HEAD
259	R44881800	S86NX POWER CABLE ASSY	POWER UNIT (J4) - CONT PCB (CN29) POWER UNIT (J2) - CONT PCB (CN2)
		ABCD	CONT PCB (CN14)
A	R40887901	S84-86NX SENSOR CABLE SET-LF	- FEED SENSOR, PITCH SENSOR
B	R40891200	S84-86NX-HO SENSOR CABLE SET-LF	- HO SENSOR
C	R40887101	S84-86NX COVER SWITCH CABLE SET-LF	- TOP COVER SWITCH
D	R40891100	S84-86NX-R SUPPLY CABLE SET-LF	- R SUPPLY SENSOR

Drawing