

## CG4XX SERVICE PARTS LIST

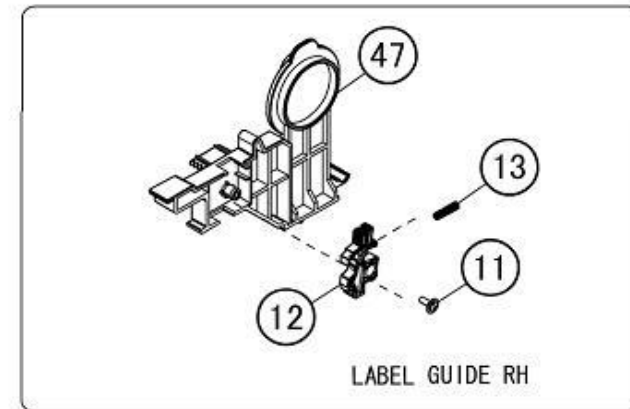

Create Date:

SATO CORPORATION . TOKYO. JAPAN

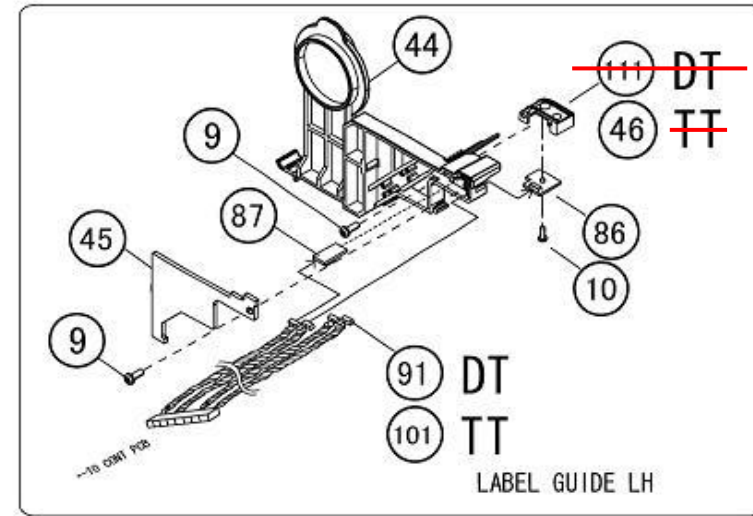
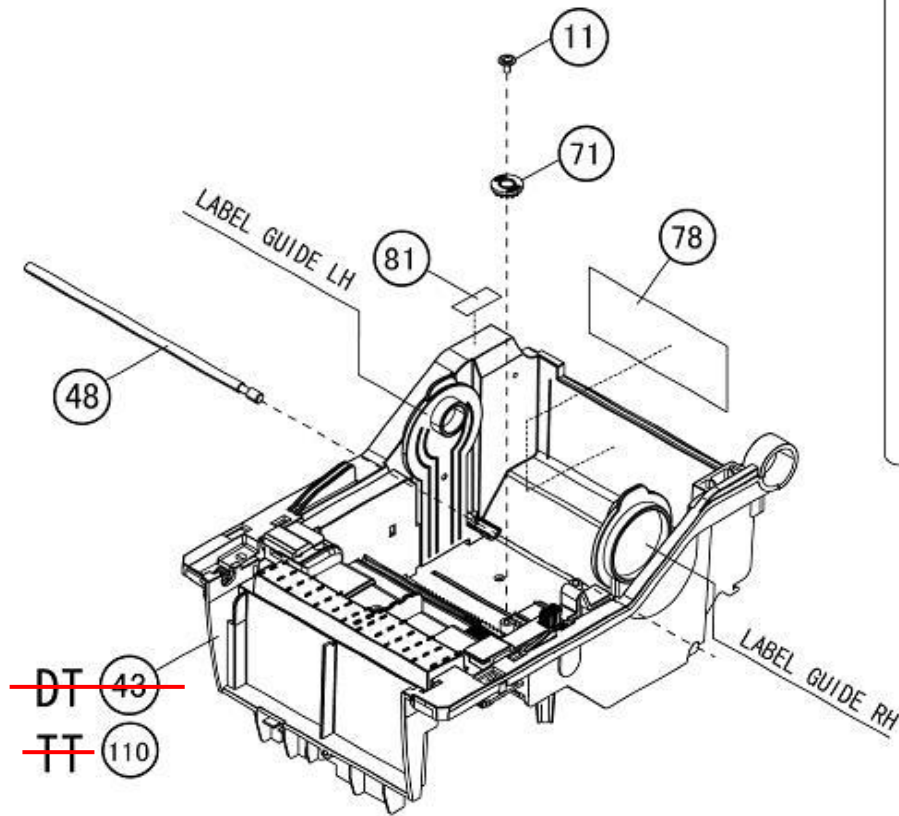

DESCRIPTION  
Fig01-ASSY

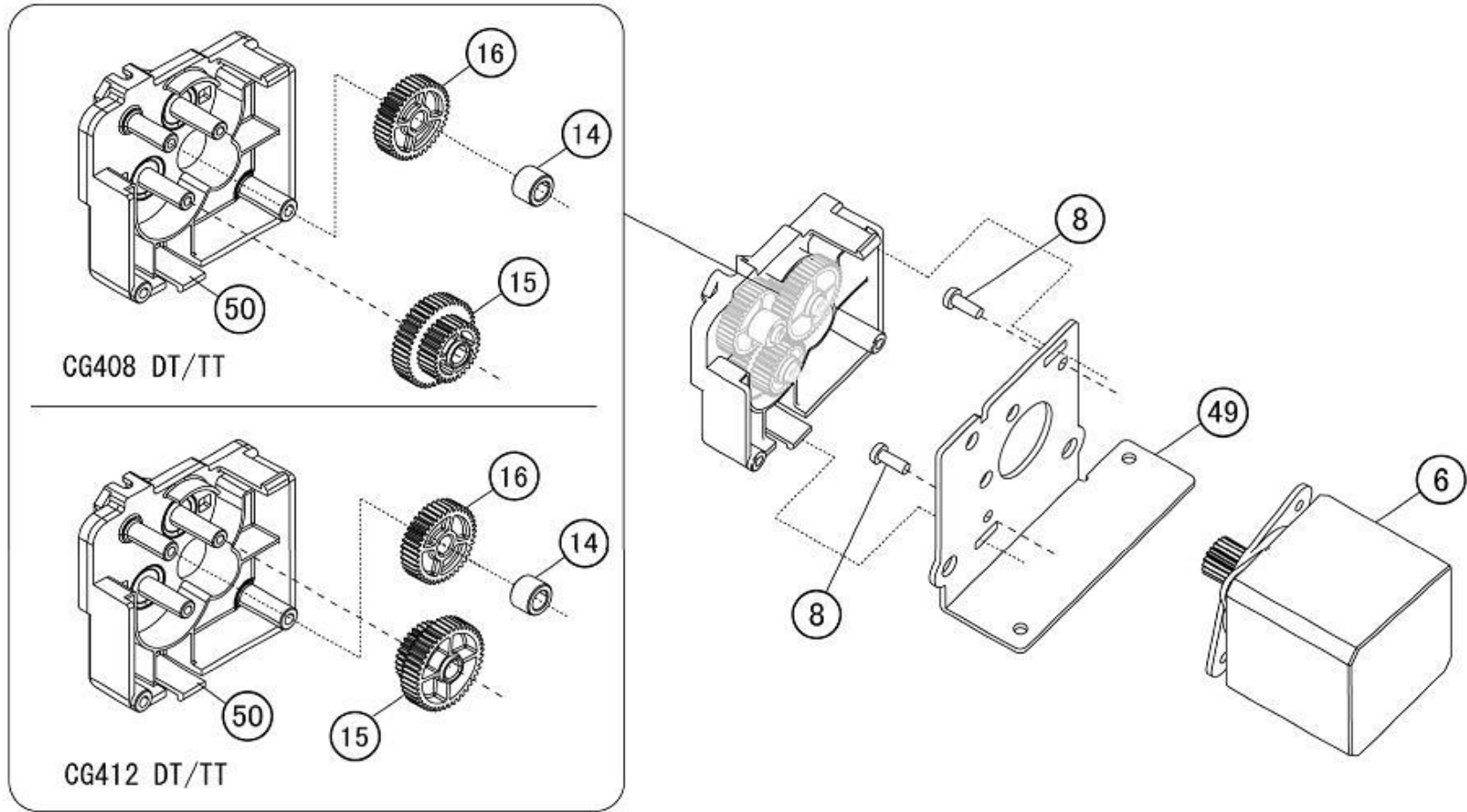

DESCRIPTION  
Fig02-ASSY

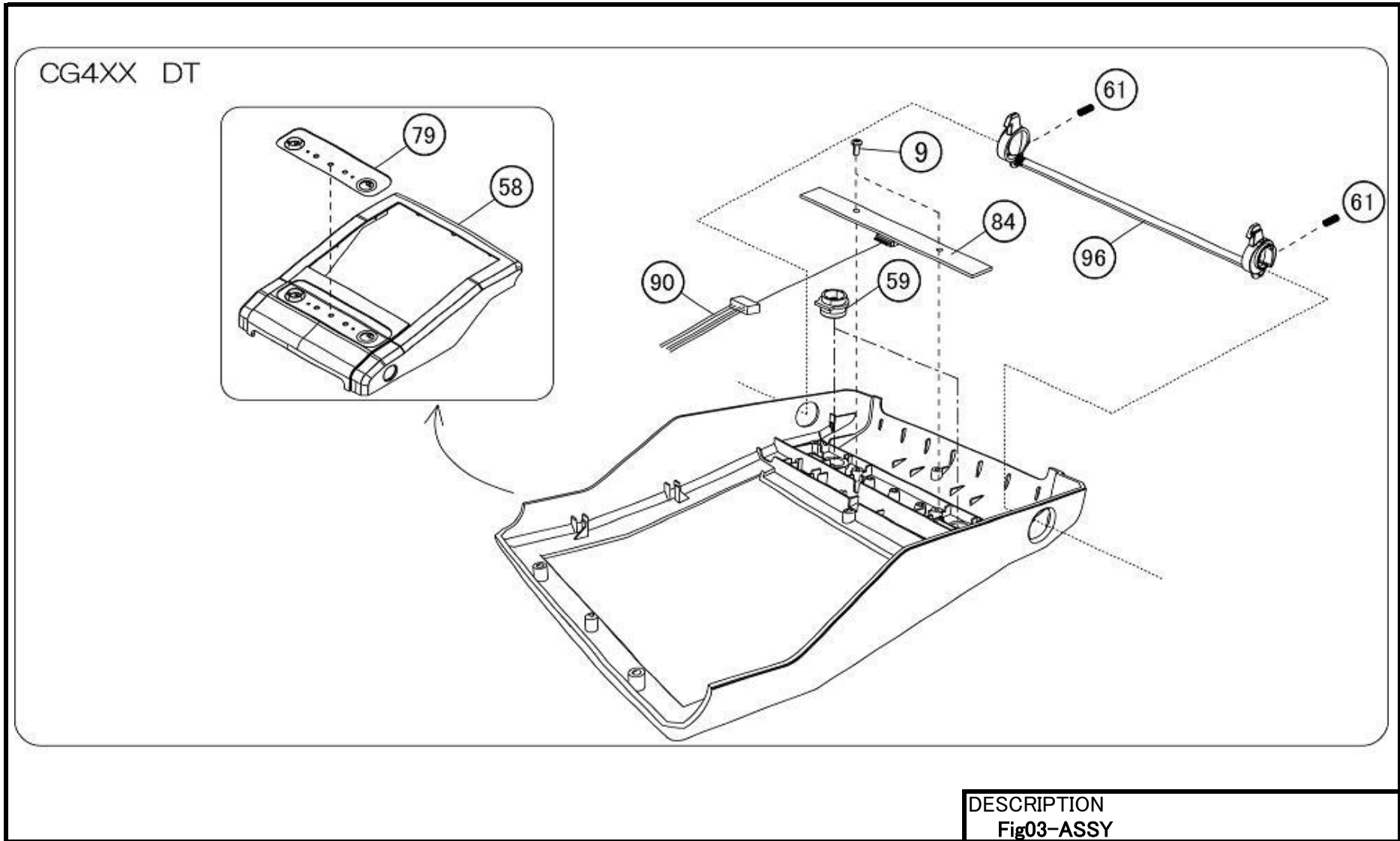

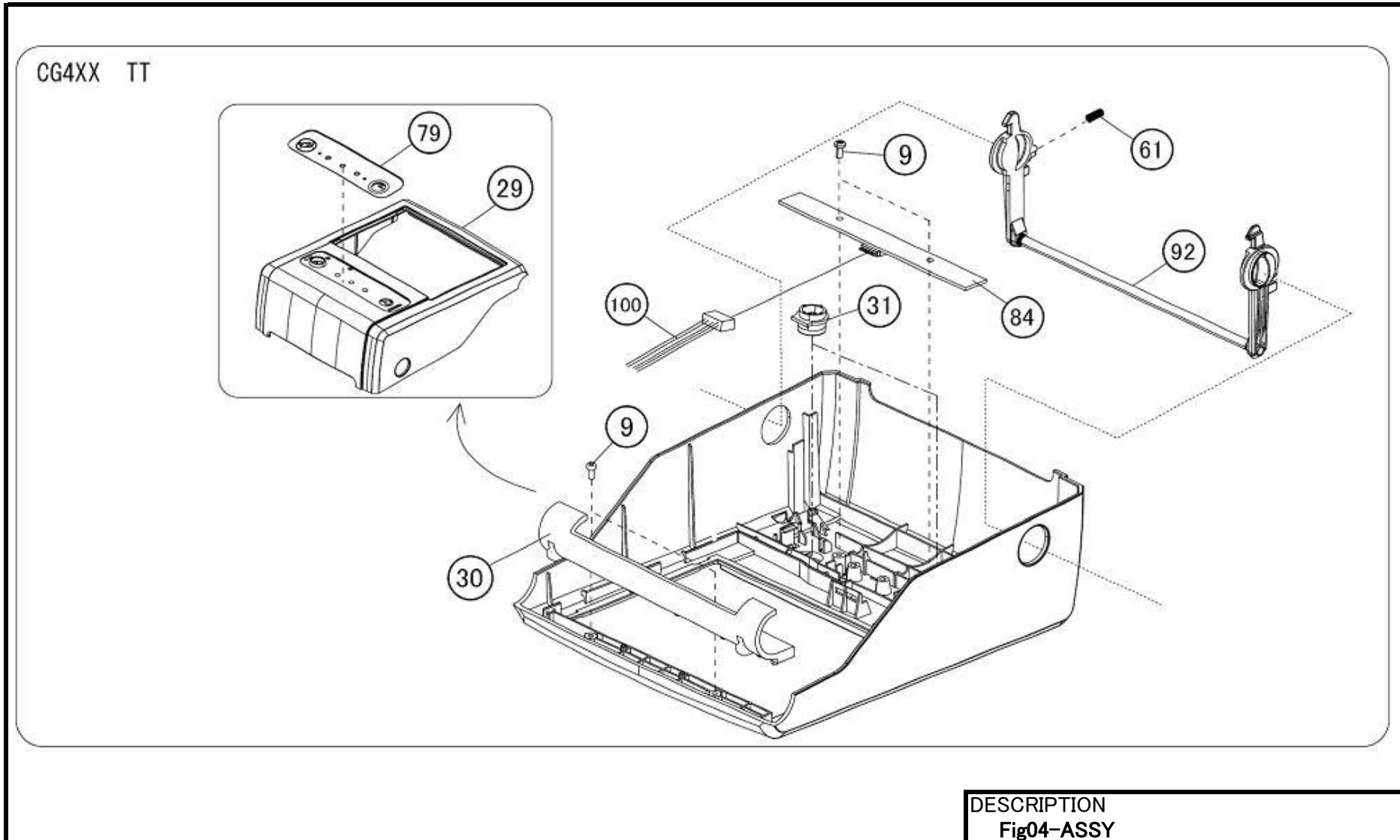

CG4XX DT

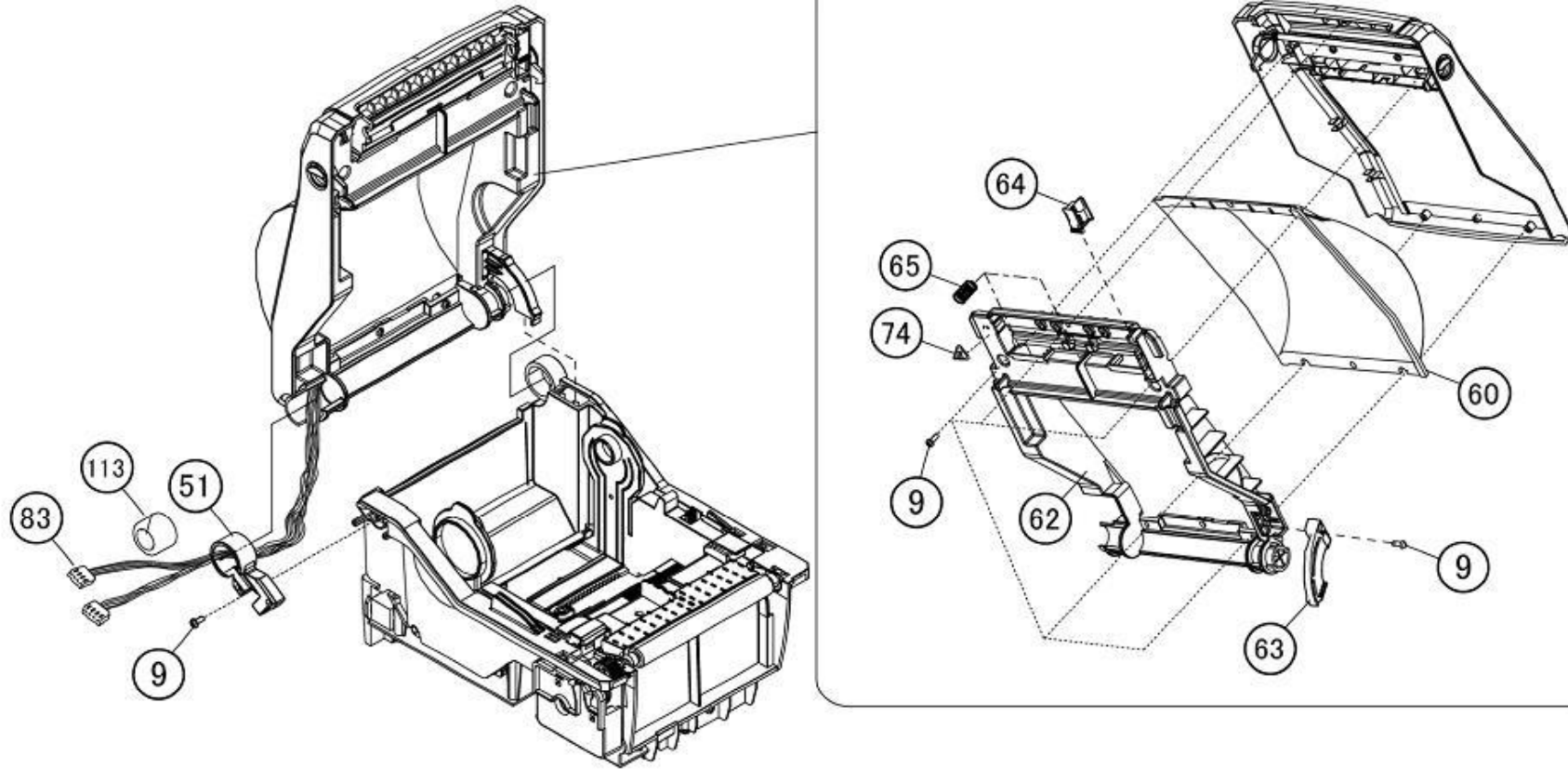

DESCRIPTION  
Fig05-ASSY

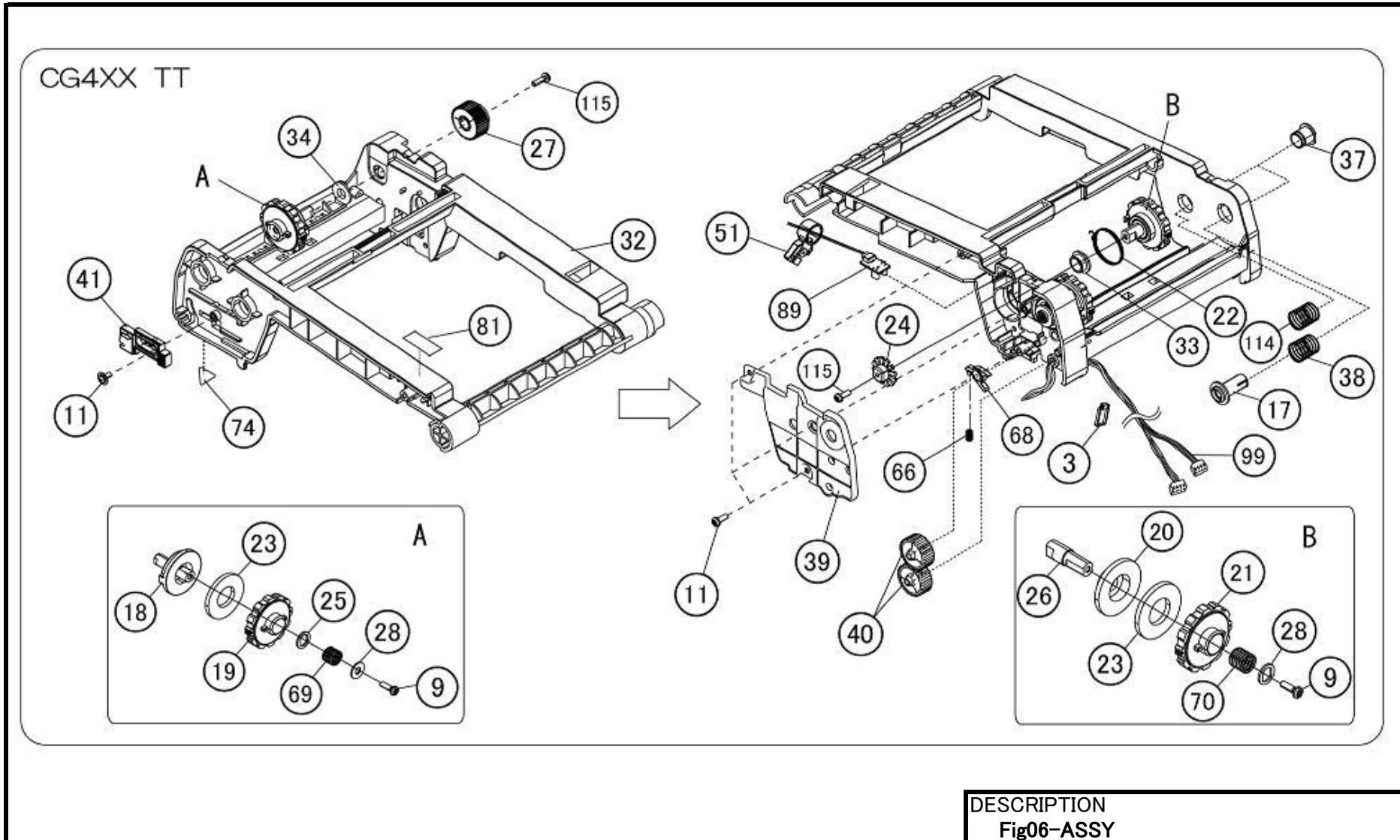

CG4XX TT

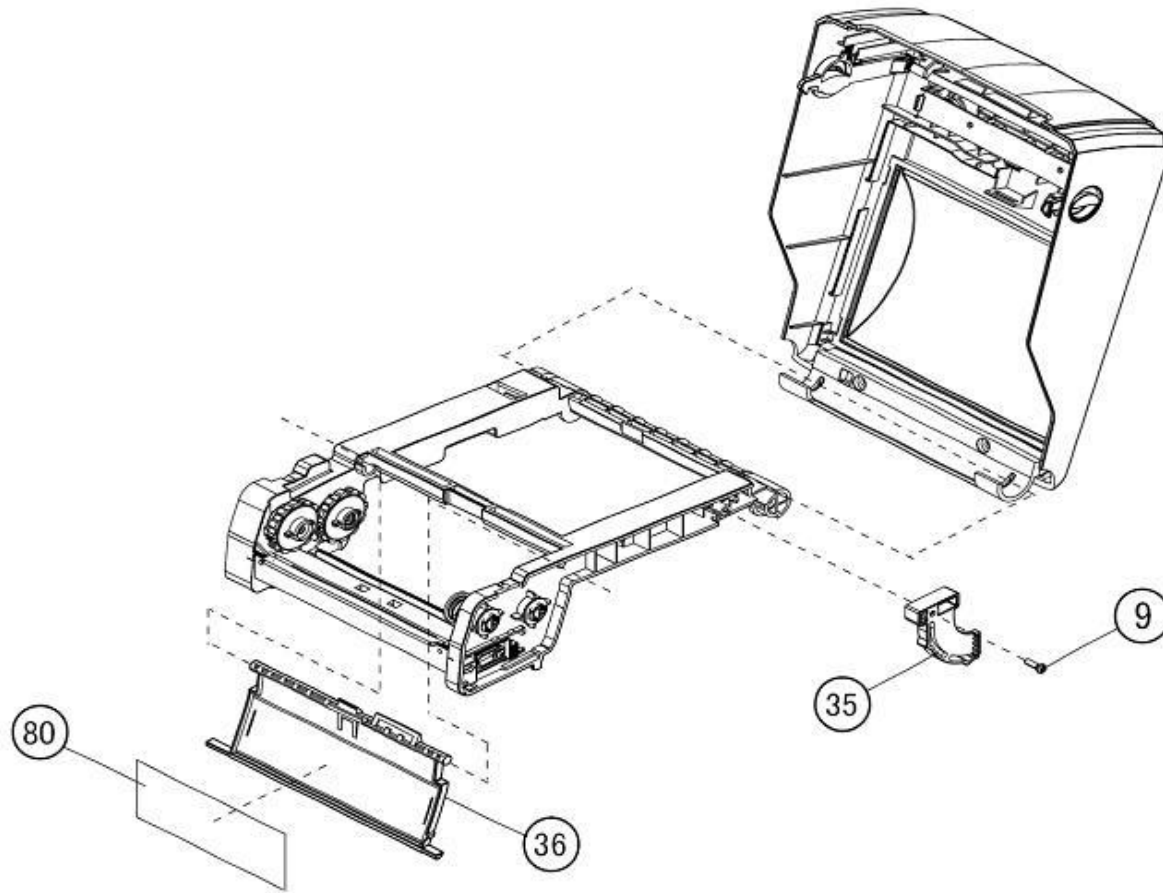

DESCRIPTION  
Fig07-ASSY

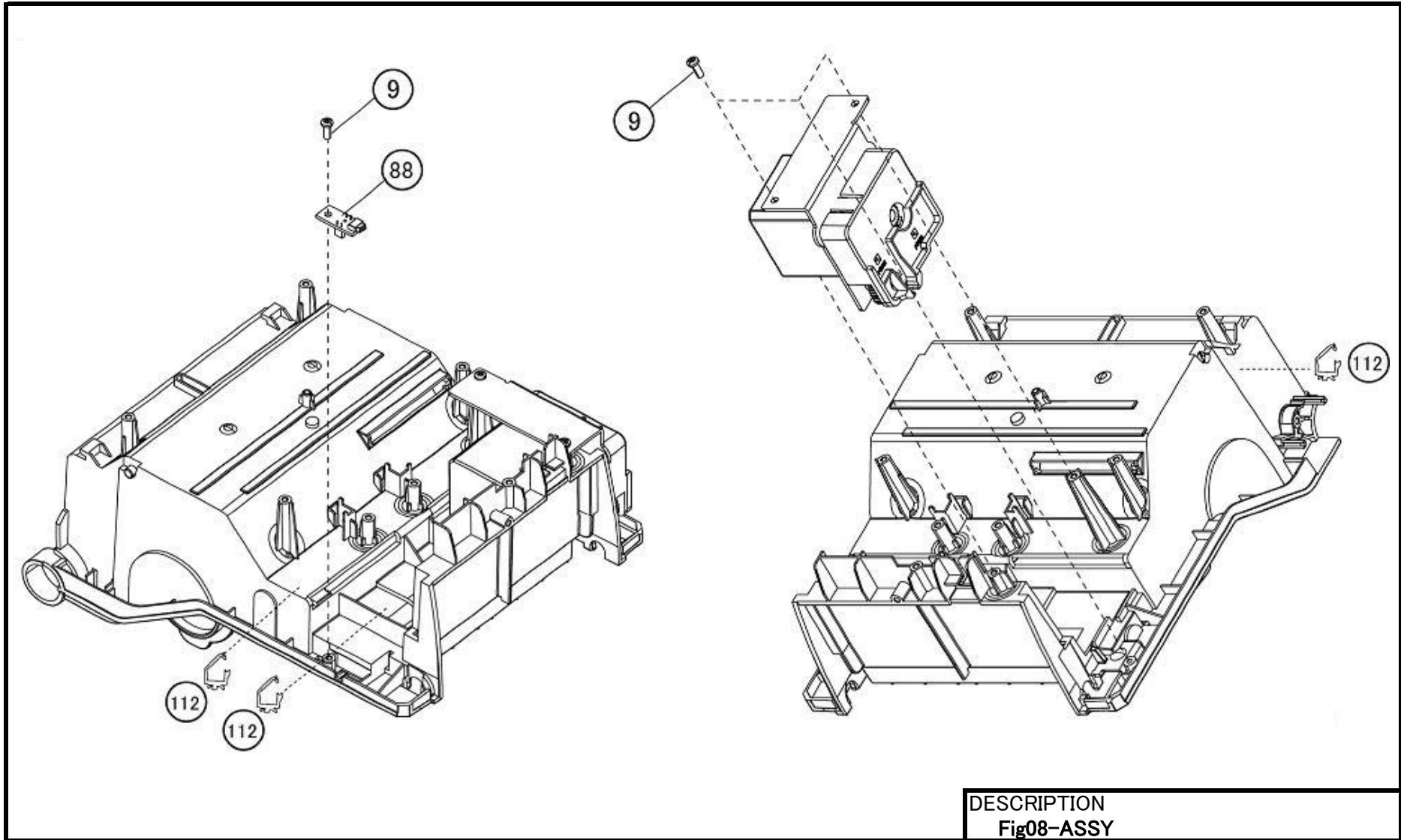

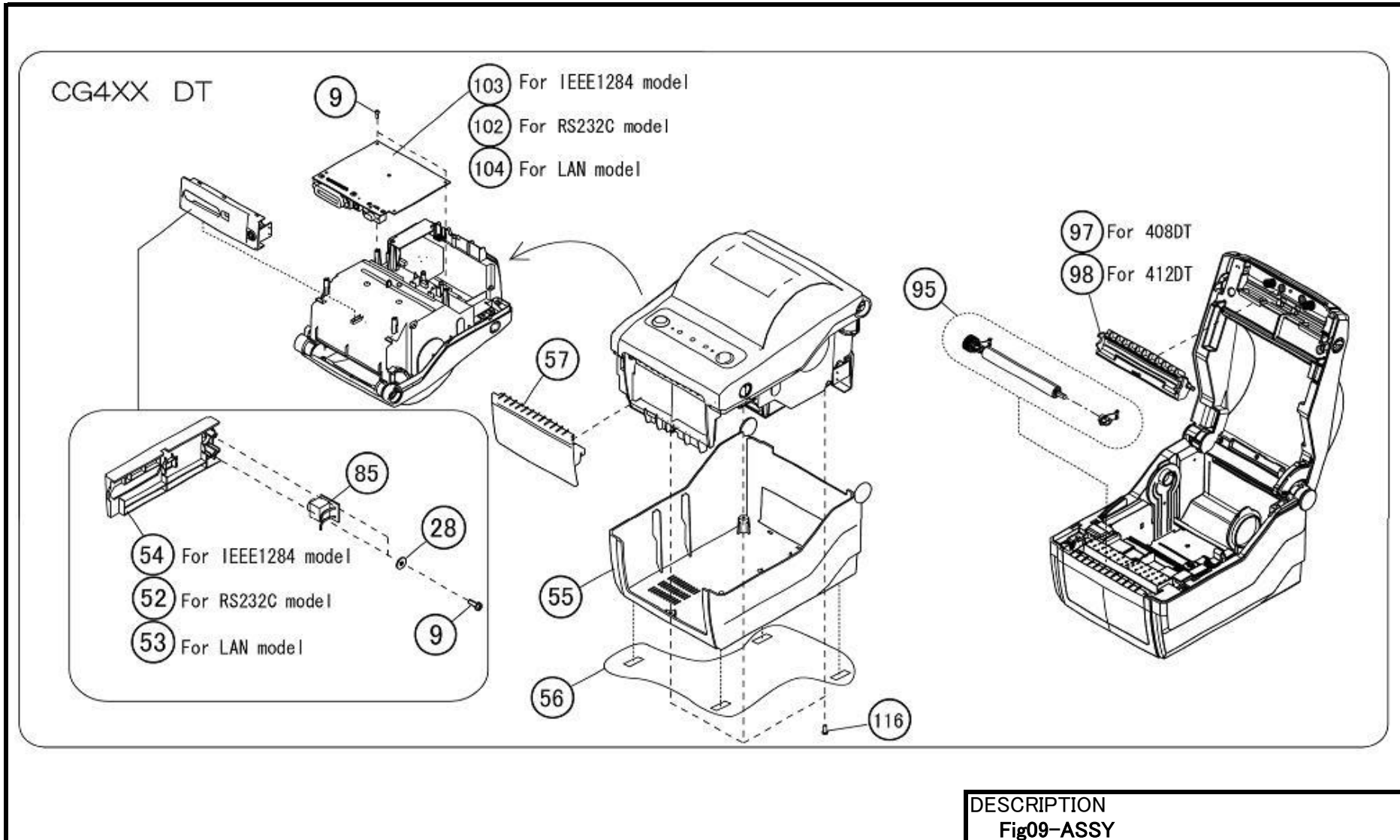

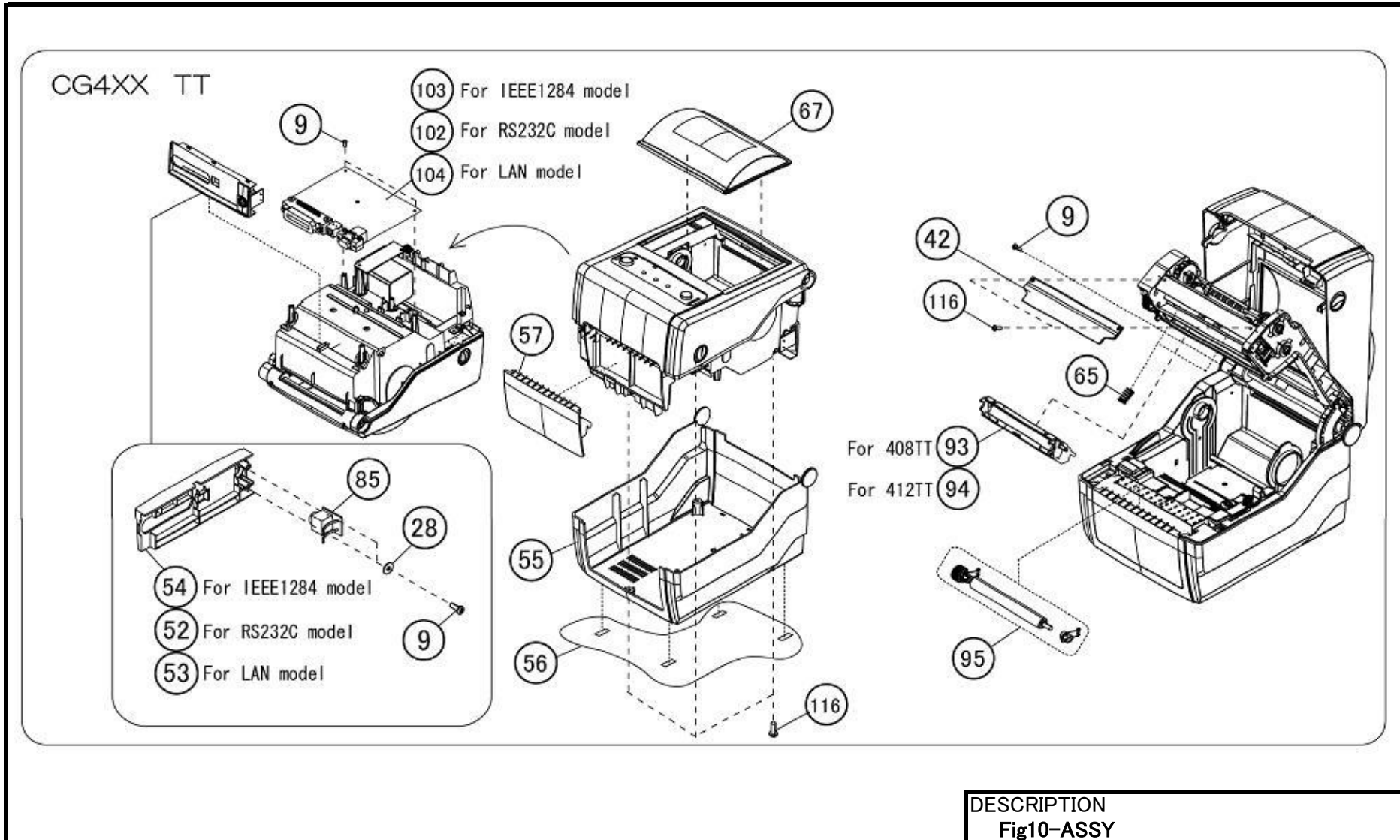

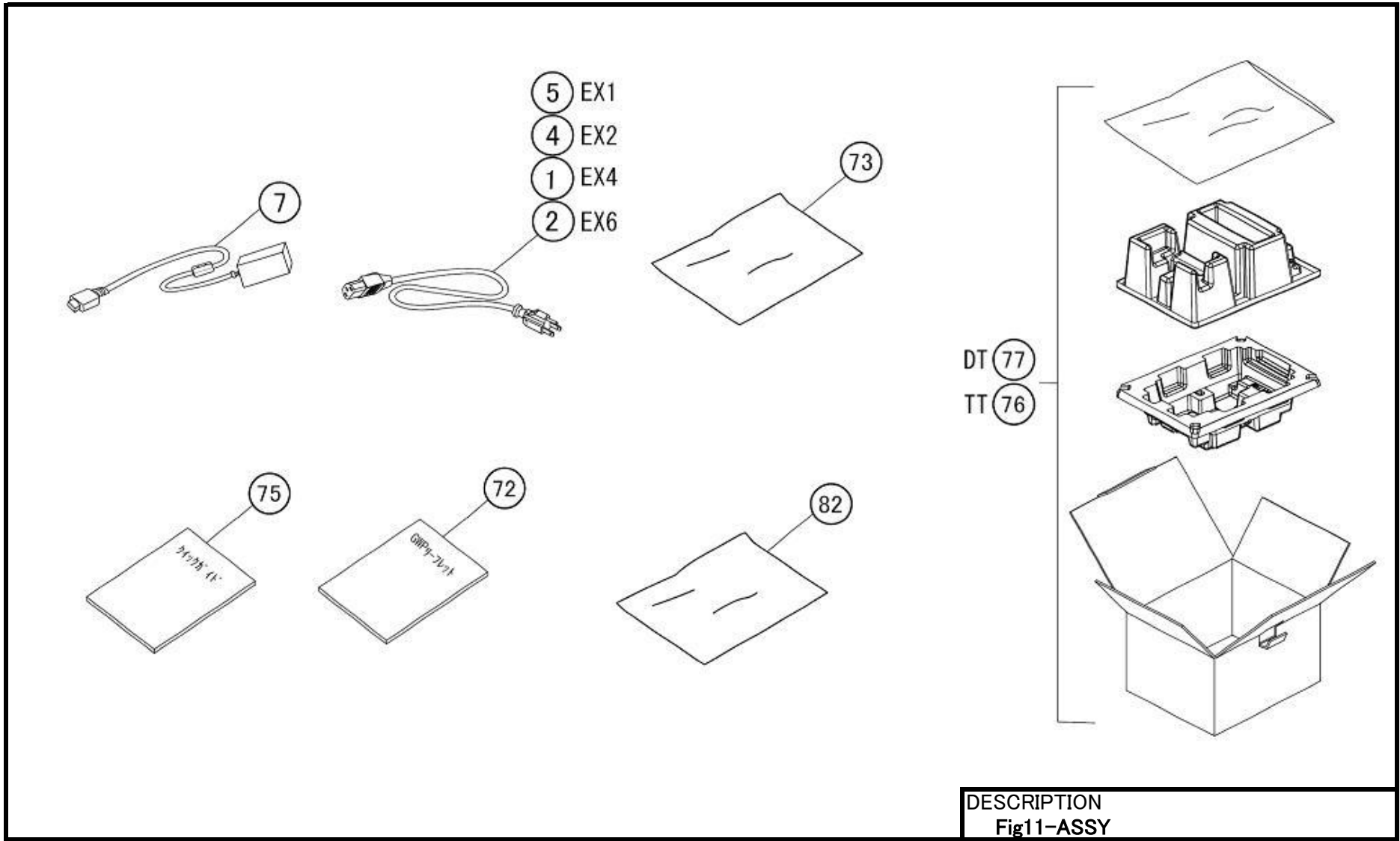

DESCRIPTION  
Fig11-ASSY

CG4XX SERVICE PARTS LIST

AssyName ASSY

NO	First_Code	Description	Standard	Std_List Price	NOTE
1	H00364001	POWER CORD			Fig11/Recommended spare parts
2	H01563000	POWER CORD-LF			Fig11
3	JG100011A	TIE WRAP			Fig06
4	JH000451A	AC POWER CORD ASSY			Fig11
5	JH000441A	AC CABLE(1-)			Fig11
6	K00292000	STEPPING MOTOR			Fig02/Recommended spare parts
7	K00550606	AC ADAPTOR-LF			Fig11/Recommended spare parts
8	MD4300822	PAN HEAD SCREW+SW+WL			Fig02
9	MH0300822	PAN HEAD P TIGHT SCREW			Fig01,03,04,05,06,07,08,09,10
10	M16249000	BIND HEAD P TIGHT SCREW			Fig01
11	MH9300822	PAN HEAD P TIGHT SCREW			Fig01,06
12	P27066000	GUIDE STOPPER			Fig01
13	P27067000	SPRING(G.STOPPER)			Fig01
14	P27072000	SPACER			Fig02
15	P27073000	DOUBLE GEAR(Z45*Z30)			Fig02
16	P27074000	GEAR(Z40)			Fig02
17	P27101030	CORE GUIDE			Fig06
18	P27105010	TQ.LIMITER PLATE A(R)			Fig06
19	P27106000	TQ.LIMITER PLATE B(R)			Fig06
20	P27108000	TQ.LIMITER PLATE A(U)			Fig06
21	P27109000	TQ.LIMITER PLATE B(U)			Fig06
22	P27111010	TORSION SPRING			Fig06
23	P27112000	FELT PLATE			Fig06/Recommended spare parts
24	P27113000	ENCODER			Fig06
25	P30662000	TQ.LIMITER WASHER			Fig06
26	P30663000	SHAFT(ENCODER)			Fig06
27	P31066000	CLUTCH-GEAR			Fig06/Recommended spare parts
28	P31363000	WASHER(d3.3*D9*t0.8)			Fig06,09,10
29	P32644021	TOP COVER(TT)			Fig04
30	P32648000	TOP COVER HINGE			Fig04
31	P32649011	BUTTON(TT)			Fig04
32	P32652080	RIBBON FRAME			Fig06
33	P32653010	RIBBON BUSH(U)			Fig06
34	P32654010	RIBBON BUSH(R)			Fig06
35	P32656011	SWING STOPPER(TT)			Fig07
36	P32657012	RIBBON COVER			Fig07
37	P32659010	CORE GUIDE BUSH			Fig06
38	P36056000	SPRING(CORE GUIDE)			Fig06
39	P32662011	GEAR COVER			Fig06
40	P32663000	GEAR(IDLE)			Fig06
41	P32664020	HEAD RELEASE LEVER(TT)			Fig06
42	P32666011	R ADJUST PLATE			Fig10
43	R16570040	BOTTOM FRAME SA			Same as No.110:R14466020
44	P32670011	LABEL GUIDE L			Fig01
45	P32671011	GUIDE COVER L			Fig01

CG4XX SERVICE PARTS LIST

AssyName      ASSY

NO	First_Code	Description	Standard	Std_List Price	NOTE
46	P32672002	SENSOR COVER			Fig01
47	P32673012	LABEL GUIDE R			Fig01
48	P32674000	SHAFT(LABEL GUIDE)			Fig01
49	P32675000	MOTOR BRACKET			Fig02
50	P32676011	GEAR BOX			Fig02
51	P32678011	BOTTOM FRAME HINGE			Fig05,06
52	P32680011	REAR I/F PANEL(RS232C)			Fig09,10
53	P32680111	REAR I/F PANEL(LAN)			Fig09,10
54	P32680211	REAR I/F PANEL(IEEE1284)			Fig09,10
55	P32683011	BOTTOM COVER			Fig09,10
56	P32684000	RUBBER FOOT			Fig09,10
57	P32685011	FRONT PANEL(STD)			Fig09,10
58	P32686020	TOP COVER(DT)			Fig03
59	P32688011	BUTTON(DT)			Fig03
60	P32690001	WINDOW(DT)			Fig05
61	P32693001	SPRING(OPEN LEVER)			Fig03,04
62	P32694020	TOP FRAME			Fig05
63	P32695011	SWING STOPPER(DT)			Fig05
64	P32696010	HEAD RELEASE LEVER(DT)			Fig05
65	P32697010	SPRING(HEAD)			Fig05,10
66	P32814000	SPRING(GEAR STOPPER)			Fig06
67	P32825002	WINDOW(TT)			Fig10
68	P32829010	GEAR STOPPER			Fig06
69	P32888000	TQ.SPRING(R)			Fig06
70	P33423010	TQ.SPRING(U)			Fig06
71	PJ0A20500	GEAR(L.GUIDE)			Fig01
72	Q01013003	GWP-LEAFLET			Fig11
73	Q01721000	POLY BAG(500*120*0.05)			Fig11
74	Q02348000	STICKER(HEAT CAUTION)			Fig05,06
75	Q02444000	QUICK GUIDE(1st EDITION)			Fig11
76	Q02445010	PACKING SET(TT)			Fig11
77	Q02490010	PACKING SET(DT)			Fig11
78	Q02578000	STICKER(LABEL ROUTE)			Fig01
79	Q02579000	OPERATION SHEET			Fig03,04
80	Q02580000	STICKER(RIBBON ROUTE)			Fig07
81	Q02589000	STICKER(CAUTION)			Fig01
82	QB2042336	CUSHION			Fig11
83	R12875010	HEAD CABLE SET(DT)-LF			Fig05
84	R12991000	KB PCB SET-LF			Fig03,04/Recommended spare parts
85	R12999000	DC POWER CABLE SA-LF			Fig09,10
86	R13004000	IM&GAP PCB SET-LF			Fig01/Recommended spare parts
87	R13005000	GAP PCB SET-LF			Fig01/Recommended spare parts
88	R16252000	COVER SENSOR PCB SET-LF			Fig8/Recommended spare parts
89	R16253000	RIBBON SENSOR PCB SET-LF			Fig06/Recommended spare parts
90	R14263010	KB CABLE SET(DT)-LF			Fig03

## CG4XX SERVICE PARTS LIST

AssyName      ASSY

NO	First_Code	Description	Standard	Std_List Price	NOTE
91	R14265010	SENSOR CABLE SET(DT)-LF			Fig01
92	R14461012	OPEN LEVER SET(TT)			Fig04
93	R14464020	PRINT HEAD (8 DPMM) CG408TT			Fig010/Recommended spare parts
94	R14465020	PRINT HEAD (12DPMM) CG412TT			Fig010/Recommended spare parts
95	R14471010	PLATEN ROLLER SAB CG4XTT/DT			Fig09,10/Recommended spare parts
96	R14480021	OPEN LEVER SET(DT)			Fig03
97	R14481011	PRINT HEAD (8 DPMM) CG408DT			Fig09/Recommended spare parts
98	R14482011	PRINT HEAD (12 DPMM) CG412DT			Fig09/Recommended spare parts
99	R15041000	HEAD CABLE SET(TT)-LF			Fig06
100	R15048000	KB CABLE SET(TT)-LF			Fig04
101	R15050010	SENSOR CABLE SET(TT)-LF			Fig01
102	R15396002	MAIN PCB (RS232C) CG4XTT/DT			Fig09,10/Recommended spare parts
103	R15397002	MAIN PCB (IEEE1284) CG4XTT/DT			Fig09,10/Recommended spare parts
104	R15398002	MAIN PCB (LAN) CG4XTT/DT			Fig09,10
110	R14466020	BOTTOM FRAME SET			Fig01
111	R16522001	SENSOR COVER SET			Same as No.46:P32672002
112	H03284000	CABLE CLAMP			Fig08
113	J00056000	SPIRAL TUBE(25)			Fig05
114	P36625000	SPRING(CORE GUIDE U)			Fig06
115	MH0301221	PAN HEAD P TITE SCREW			Fig06
116	MH2301022	BIND HEAD P TIGHT SCREW			Fig10

DATE: 25 Jan, 2010



## CG4XX CUTTER KIT SERVICE PARTS LIST

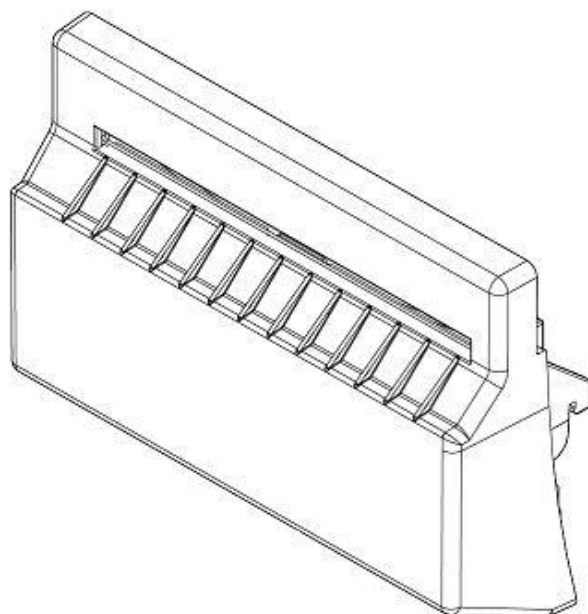

Create Date:

WWCG05100

RV09-621

SATO CORPORATION . TOKYO. JAPAN

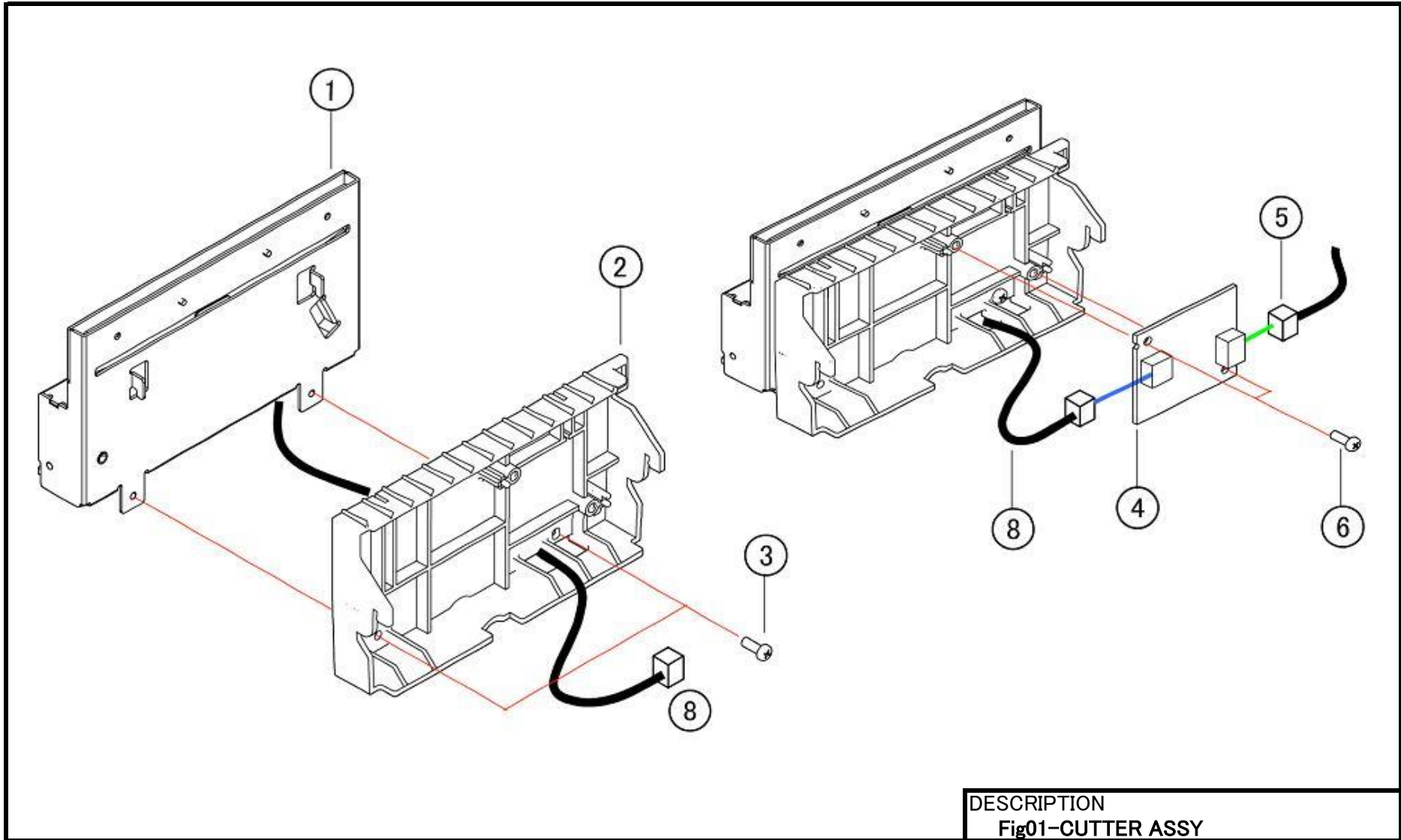

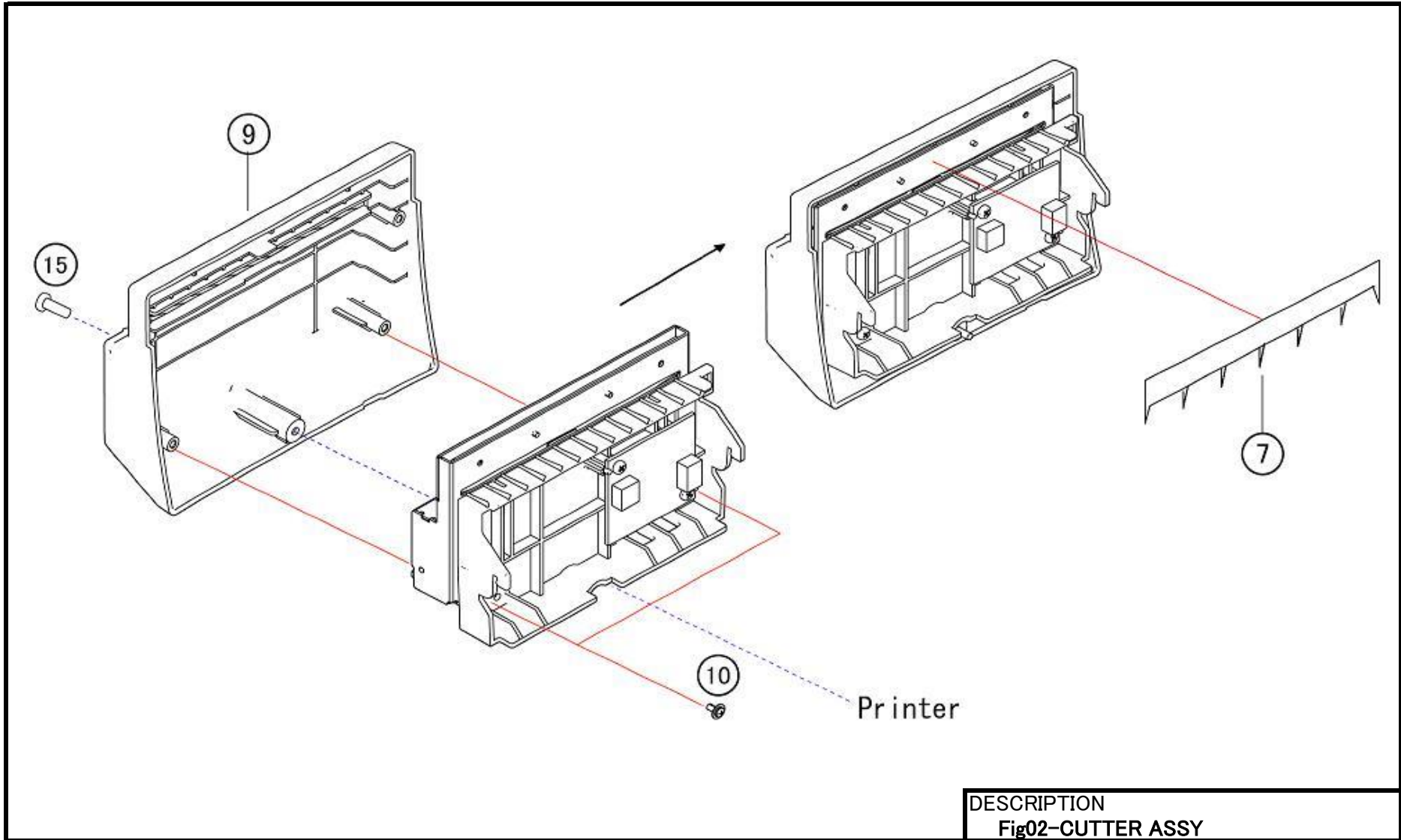

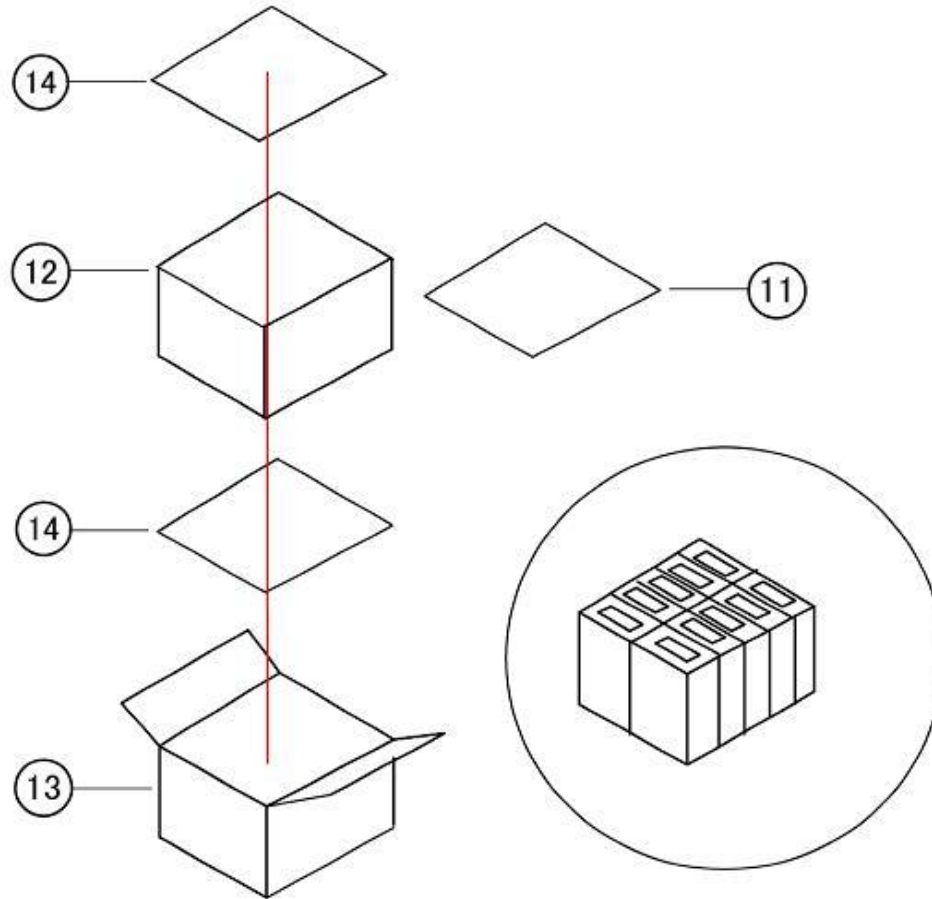

DESCRIPTION  
Fig03-CUTTER ASSY

## CG4XX CUTTER KIT SERVICE PARTS LIST

AssyName

	First_Code	Description	Standard	Std_List Price	NOTE
1	R15185010	CUTTER UNIT			Fig01
2	P32832031	CUTTER HOLDER			Fig01
3	MD4300822	PAN HEAD SCREW+SW+WL			Fig01
4	R17120000	CUTTER PCB SET(CG4)-LF			Fig01
5	R15069010	CUTTER CABLE SET-LF			Fig01
6	MH0300822	PAN HEAD P TIGHT SCREW			Fig01
7	P11949000	ANTI STATIC SHEET			Fig02
8	R16852000	FG CABLE SET-LF			Fig01
9	P32831013	CUTTER COVER			Fig02
10	MH0300822	PAN HEAD P TIGHT SCREW			Fig02
11	Q02236000	AIR PACKING BAG			Fig03
12	QA0A20301	P.CASE(OPTION)			Fig03
13	QA0A20201	P.CASE(OPTION20)			Fig03
14	QA0A20400	CARTON PAD			Fig03
15	MH0300822	PAN HEAD P TIGHT SCREW			Fig02

## CG4XX DISPENSER KIT SERVICE PARTS LIST

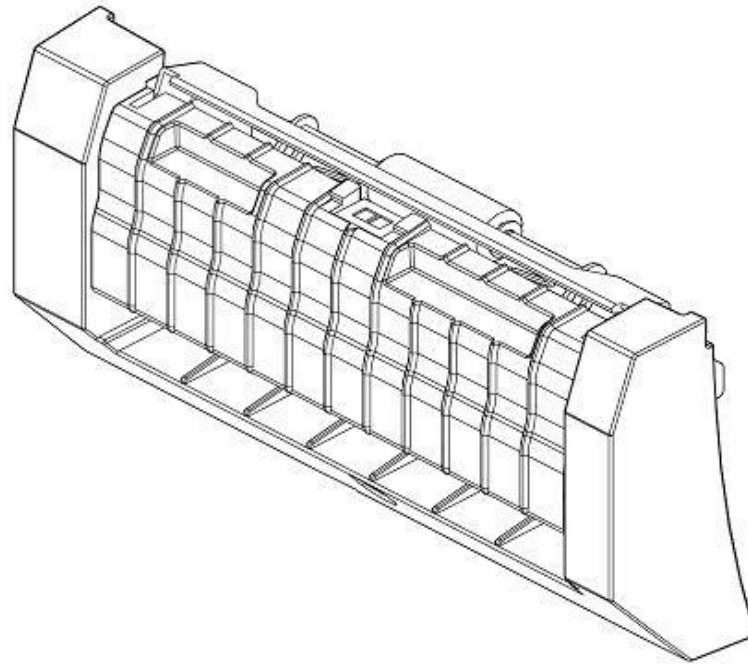

Create Date:

**WWCG05200**

**RV09-551**

**SATO CORPORATION . TOKYO. JAPAN**

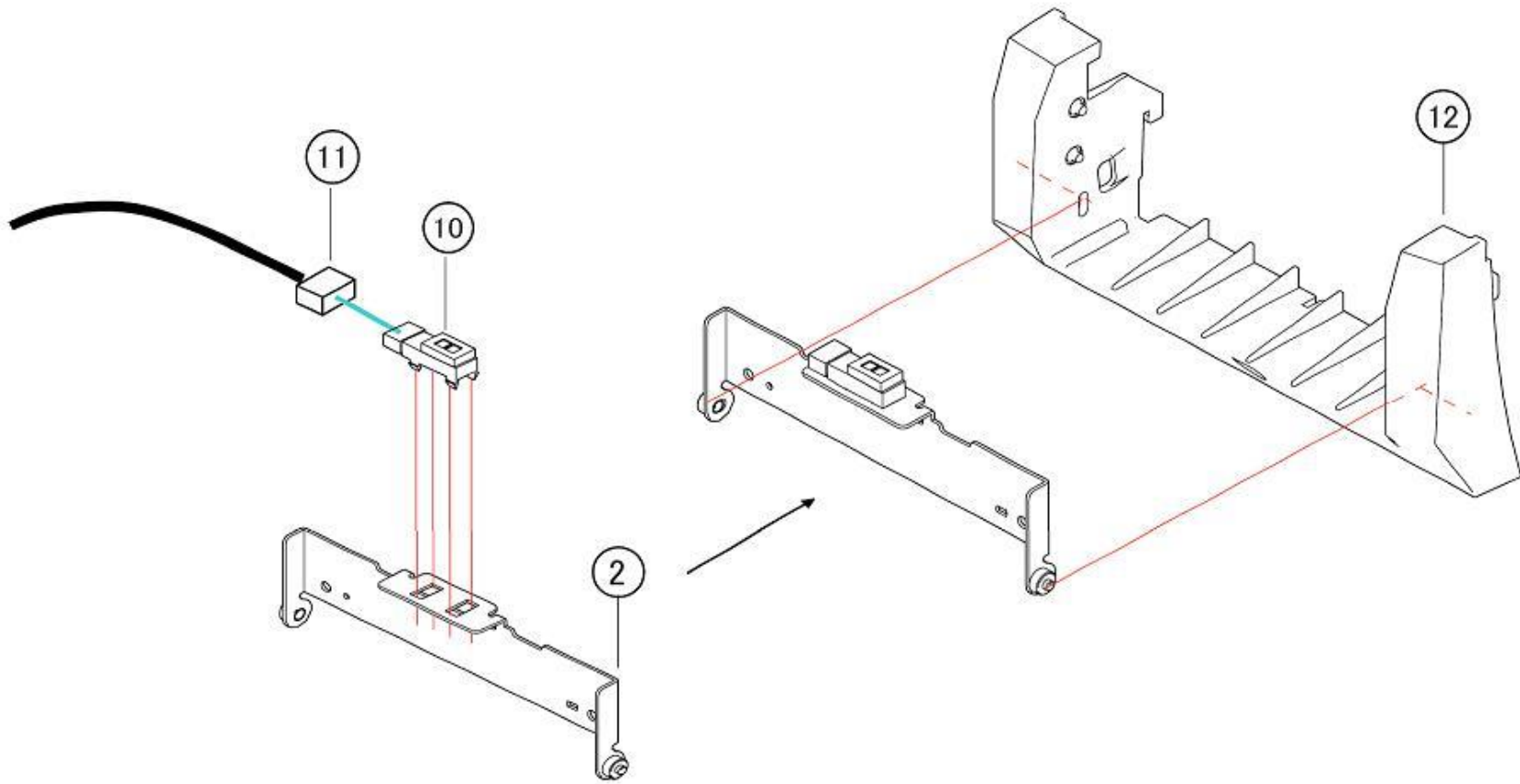

DESCRIPTION DISPENSER ASSY(01)
-----------------------------------

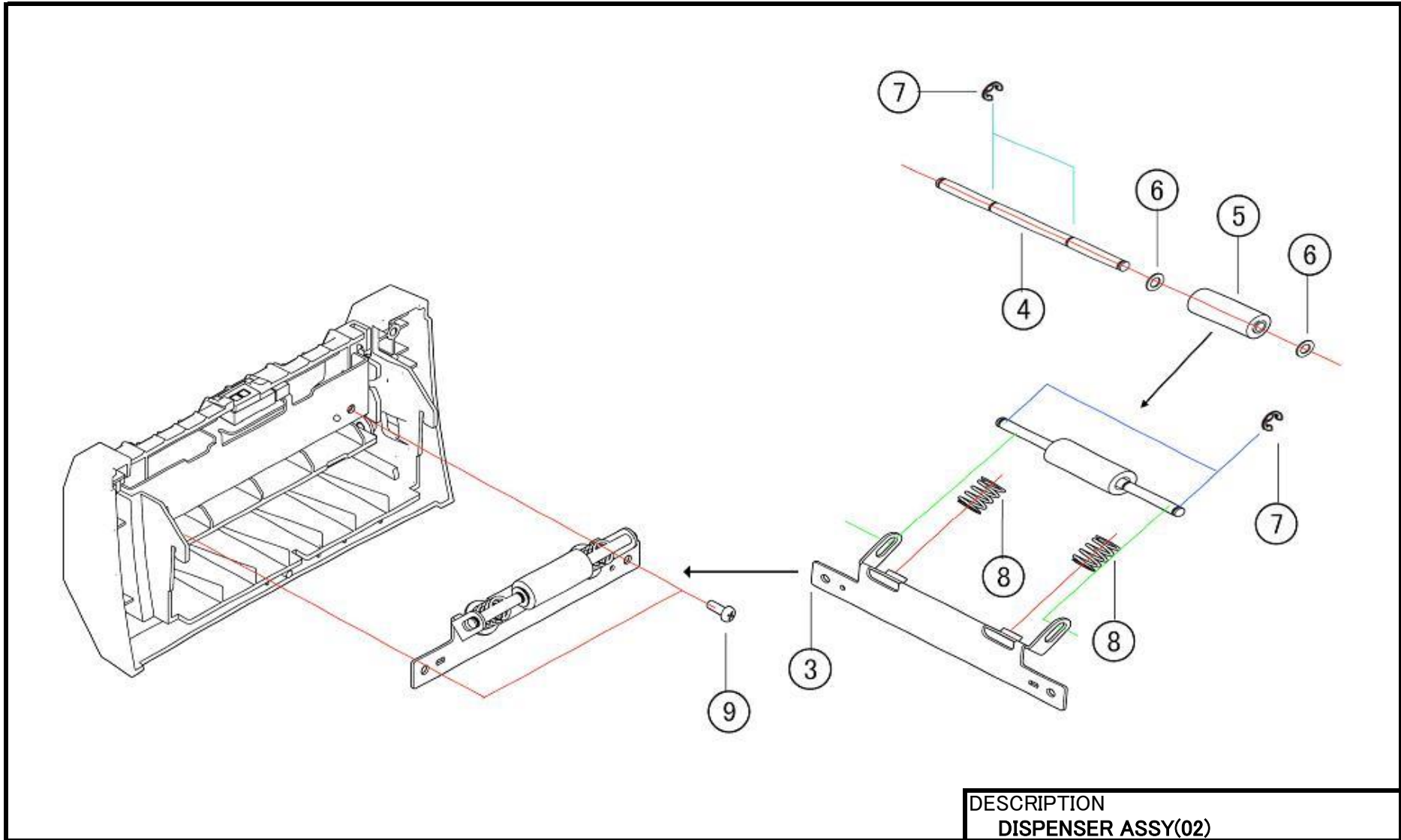

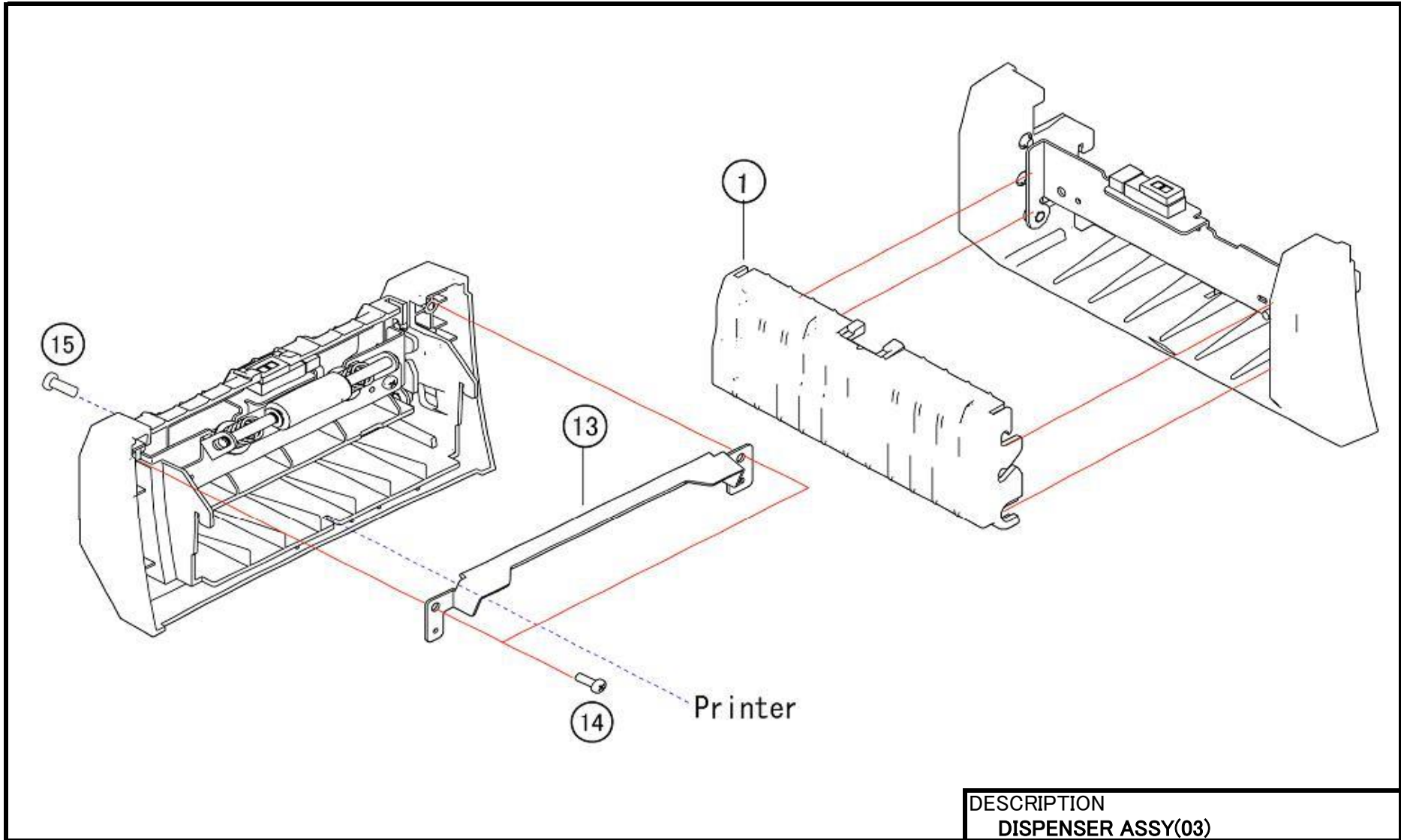

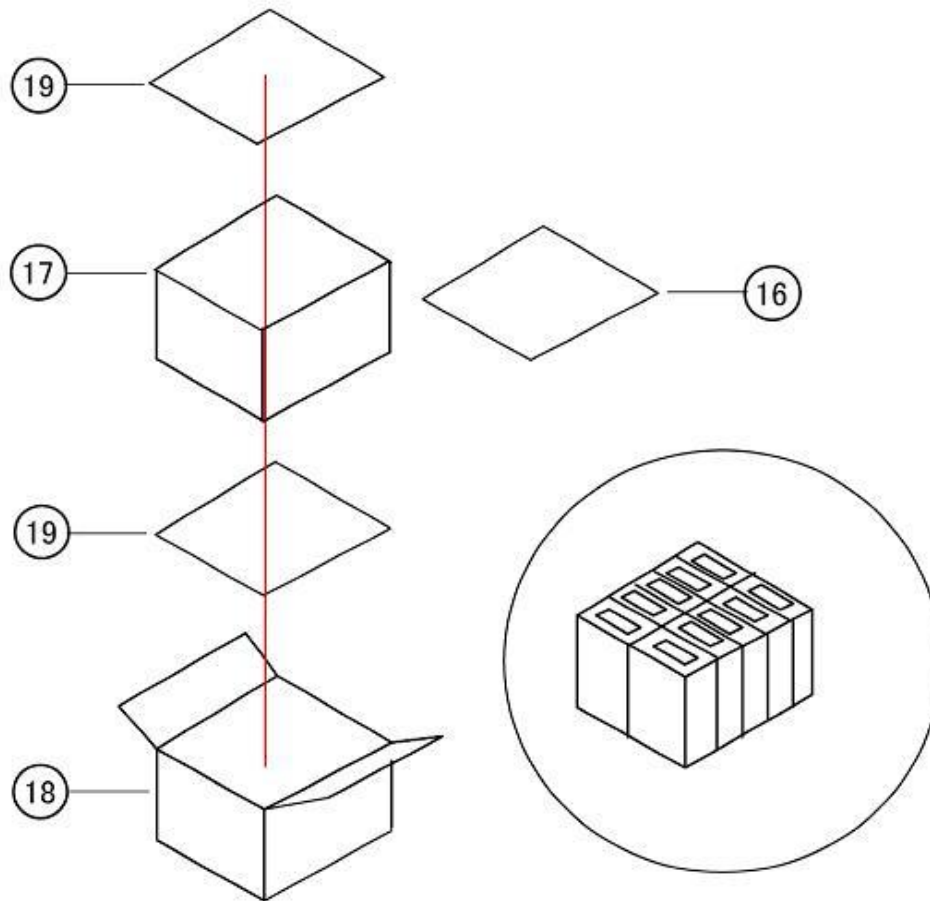

DESCRIPTION DISPENSER ASSY(04)
-----------------------------------

## CG4XX DISPENSER KIT SERVICE PARTS LIST

AssyName DISPENSER ASSY

NO	First_Code	Description	Standard	Std_List Price	NOTE
1	P32834023	DISPENSE OPEN COVER			Fig03
2	R14659010	DIS.FRAME SET			Fig01
3	P32988010	DIS.ROLLER BR.			Fig02
4	P32991000	DIS.ROLLER SHAFT			Fig02
5	P24061010	DP ROLLER			Fig02
6	NA1040022	PLAIN WASHER			Fig02
7	ND0030022	E RING 3			Fig02
8	P33048000	DIS.SPRING			Fig02
9	M16236000	BIND HEAD P TIGHT SCREW			Fig02
10	F00407000	PHOTO INTERRUPTER -LF			Fig01
11	R15089000	DISPENSER CABLE SET-LF			Fig01
12	P32833022	DISPENSE COVER			Fig01
13	P32985010	DIS.PLATE			Fig03
14	M16236000	BIND HEAD P TIGHT SCREW			Fig03
15	MH0300822	PAN HEAD P TIGHT SCREW			Fig03
16	Q02236000	AIR PACKING BAG			Fig04
17	QA0A20301	P.CASE(OPTION)			Fig04
18	QA0A20201	P.CASE(OPTION20)			Fig04
19	QA0A20400	CARTON PAD			Fig04

